

Directional seat valves, direct operated, with solenoid actuation

RE 22047-XD/04.16
Replaces: 08.12

Type M-SE 6 ...XD...

Size 6
Component series 6X
Maximum operating pressure 420 bar
Maximum flow 12 l/min



H7140

ATEX units – For potentially explosive atmospheres



Information on the explosion protection:

- ▶ Area of application in accordance with the Explosion Protection Directive 2014/34/EU: **I M2; II 2G**
- ▶ Type of protection of the valve solenoids:
Ex db I Mb / Ex db IIC T4 Gb according to EN 60079-0 / EN 60079-1

Table of contents

Contents	Page
Features	1
Ordering code	2
Function, section, symbols	3, 4
Throttle insert	5
Check valve insert	5
Technical data	6, 7
Electrical connection	8, 9
General information	9
Performance limits	10
Characteristic curves	10
Dimensions	11, 12
Installation conditions	13
Further information	14

Features

- 3/2- or 4/2-way version
- For intended use in potentially explosive atmosphere
- Porting pattern according to ISO 4401-03-02-0-05 (but without locating hole)
- Blocked connection tight
- Safe switching also with longer standstill periods under pressure
- Air-gap DC solenoids
- Electrical connection with individual connection and cable gland
- With manual override

Ordering code

M	SE	6	6X/420	L	G24	N	XD	Z2/	V
---	----	---	--------	---	-----	---	----	-----	---

Mineral oil	= M
3 main ports	= 3
4 main ports	= 4
Seat valve	
Size 6	= 6

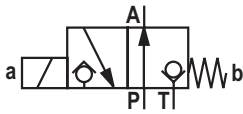
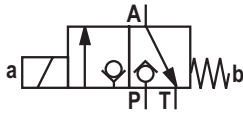
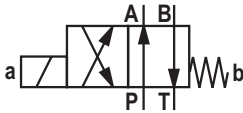
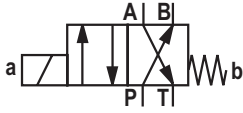
Main ports	3	4	
Symbols			
	•	—	= U
	•	—	= C
	—	•	= D
	—	•	= Y
	• = available		

Component series 60 to 69 (60 to 69: unchanged installation and connection dimensions)	= 6X
Operating pressure up to 420 bar	= 420
High-power solenoid, (air-gap)	= L

V = FKM seals (other seals upon request)
Notice:
 Observe compatibility of seals with hydraulic fluid used!

no code = Without check valve insert,
 Without throttle insert
 P = With check valve insert
 B12 = Throttle Ø 1.2 mm
 B15 = Throttle Ø 1.5 mm
 B18 = Throttle Ø 1.8 mm
 B20 = Throttle Ø 2.0 mm
 B22 = Throttle Ø 2.2 mm

Electrical connection
 Z2 = Solenoid with terminal box and cable gland,
 For details, see chapter Electrical connection

XD = Explosion protection "flameproof enclosure"
 For details, see information on the explosion protection, page 7

N = With manual override (standard)

G24 = Direct voltage 24 V

Notice:

Representation of the symbols according to DIN ISO 1219-1.

Function, section, symbols: 3/2 directional seat valve

General:

The directional valve type M-SE.. is a directional seat valve with solenoid actuation. It controls start, stop and direction of flow. It basically comprises a housing (1), the solenoid (2), the hardened valve system (3) and the balls (4.1 and 4.2) as closing element.

Basic principle:

In the initial position, the ball (4.1) is pressed onto the seat by the spring (7), in spool position, the ball (4.2) is pressed onto the seat by the solenoid (2). The force of solenoid (2) acts via the lever (17) and the ball (5) on the actuating plunger (6) that is sealed on two sides. The chamber between the two sealing elements is connected to port P. Thus, the valve system (3) is pressure-compensated in relation to the actuating forces (solenoid or return spring). Thus, the valves can be used up to 420 bar.

Notices

- The 3/2 directional seat valves have a "negative spool overlap". Therefore, port T must always be connected. This means that during the switching process – from the starting of the opening of one valve seat to the closing of the other valve seat – ports P–A–T are connected with each other. This process takes, however, place within such a short time that it is irrelevant in nearly all applications.

- The manual override (10) allows for the switching of the valve without solenoid energization.
- It has to be made sure that the specified maximum flow is not exceeded! A throttle insert must be used for flow limitation, if necessary (see page 5).
- In order to switch the valve safely or maintain it in its spool position, the pressure situation must be as follows: $P \geq A \geq T$ (for design reasons).
- The ports P, A and T (3/2 directional seat valve) are clearly determined according to the tasks. They must not be exchanged or closed. The flow is only permitted in the direction of arrow.

The seat arrangement offers the following options:

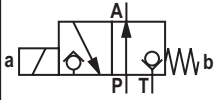
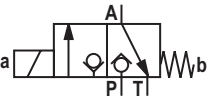
Symbol	U	C
		
Initial position	P and A connected, T blocked	P blocked, A and T connected
Spool position	P blocked, A and T connected	P and A connected, T blocked

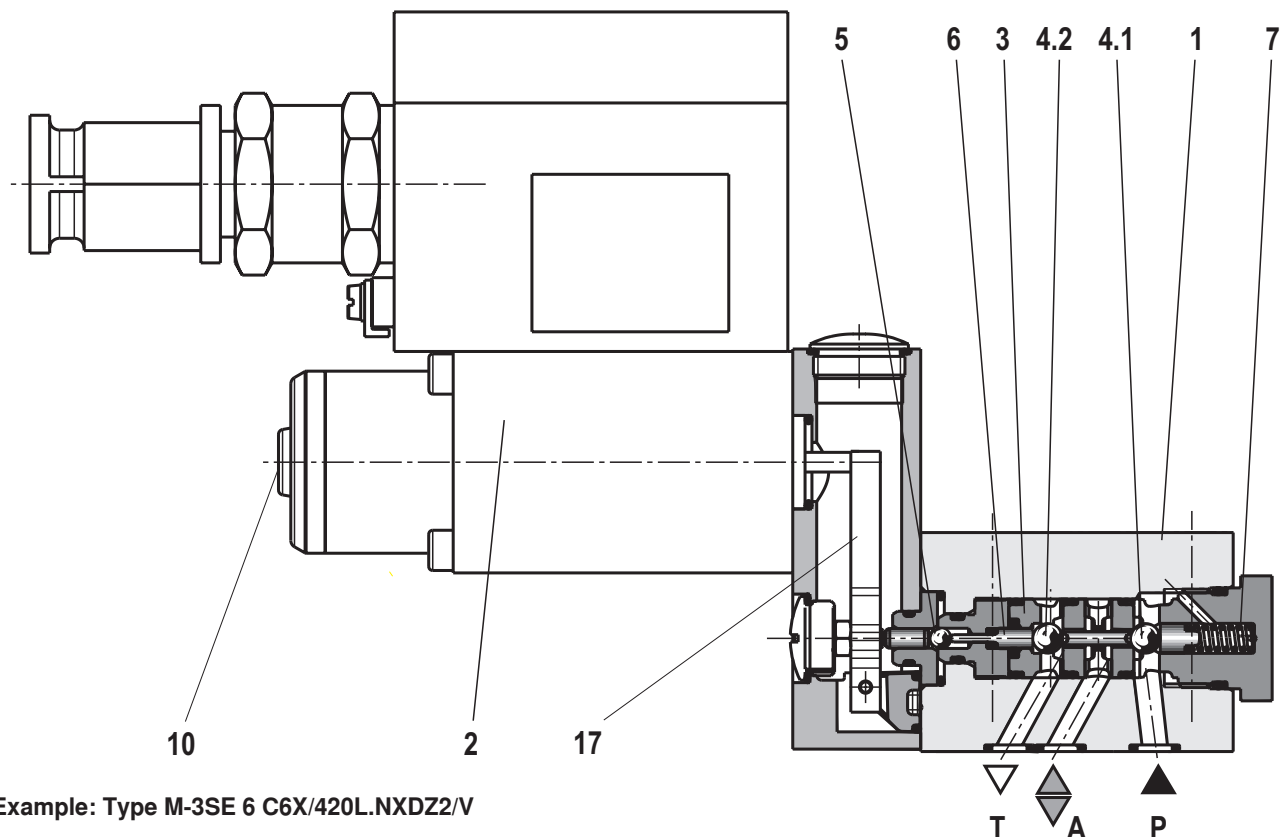

Function, section, symbols: 4/2 directional seat valve

With a sandwich plate, the **Plus-1 plate**, under the 3/2 directional seat valve, the function of a 4/2 directional seat valve is achieved.

Function of the Plus-1 plate:

Initial position:

The main valve is not actuated. The spring (7) holds the ball (4.1) on the seat (11). Port P is blocked and A is connected to T. Apart from that, one control line is connected from A to the large area of the control spool (12), which is thus unloaded to the tank. The pressure applied via P now pushes the ball (13) onto the seat (14). Now, P is connected to B, and A to T.

Transition position:

When the main valve is actuated, the control spool (8) is shifted against the spring (7) and the ball (4.2) is pressed onto the seat (15). During this, port T is blocked, P, A, and B are briefly connected to each other.

Spool position:

P is connected to A. As the pump pressure acts via A on the large area of the control spool (12), the ball (13) is pressed onto the seat (16). Thus, B is connected to T,

and P to A. The ball (13) in the Plus-1 plate has a "positive spool overlap".

The use of the Plus-1 plate and the seat arrangement offer the following options:

Symbol D:

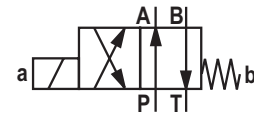

Symbol Y:

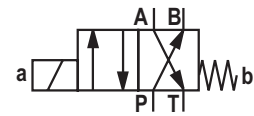

Notice:

If the annulus area of differential cylinders is not connected to port A, a pressure peak is created in port B during the switching process, which may exceed the maximum operating pressure over the permissible limit.

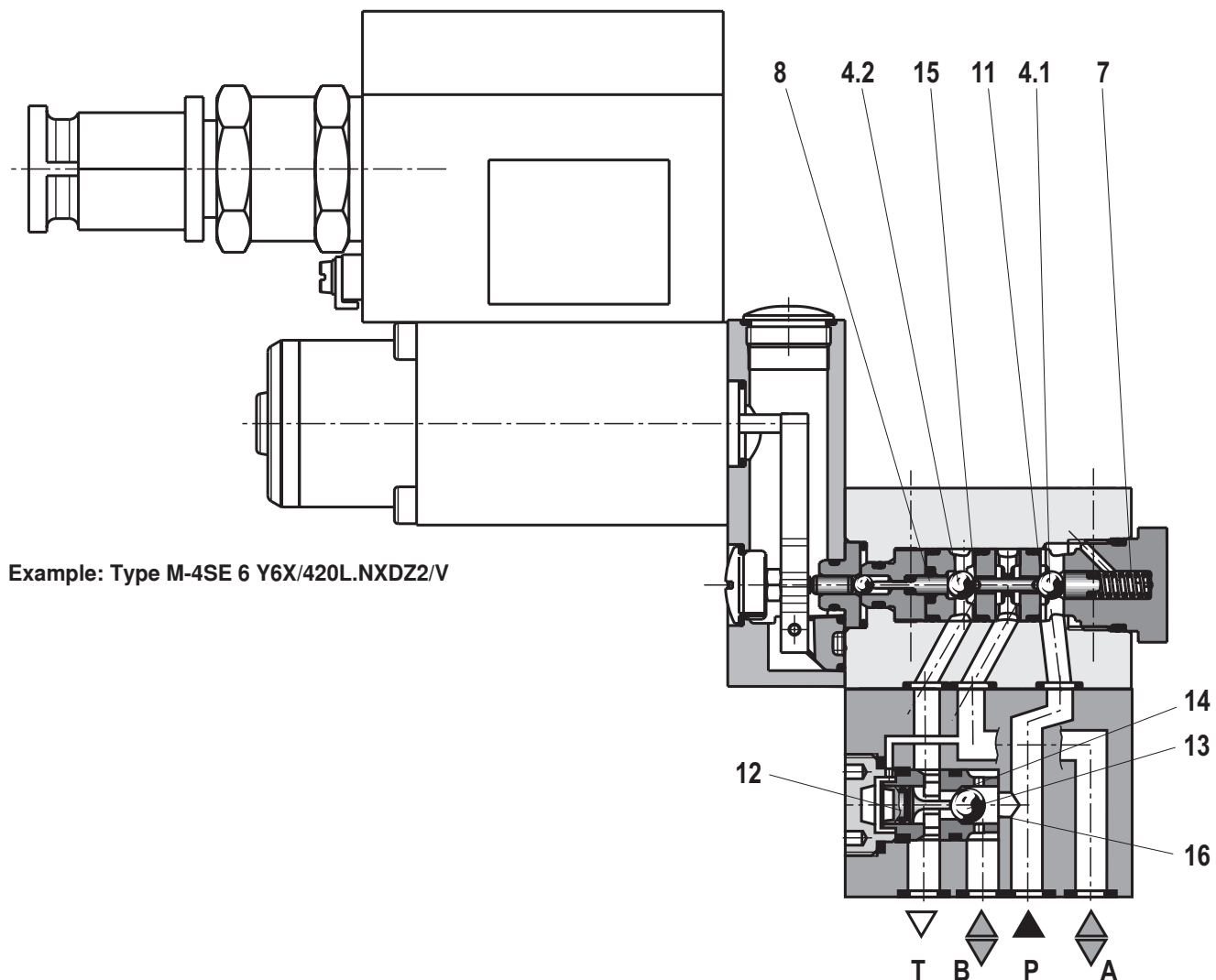

Throttle insert

The use of a throttle insert is required when due to prevailing operating conditions, flows can occur during the switching processes, which exceed the performance limit of the valve.

Examples:

- Accumulator operation,
- use as pilot control valve with internal pilot fluid tapping.

3/2 directional seat valve (see page 3)

The throttle insert is inserted in port P of the seat valve.

4/2 directional seat valve
(see page 4)

The throttle insert is inserted in port P of the Plus-1 plate.

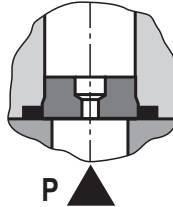

Check valve insert

The check valve insert allows free flow from P → A and closes from A → P.

3/2 directional seat valve (see page 3)

The check valve insert is inserted in port P of the seat valve.

4/2 directional seat valve
(see page 4)

The check valve insert is inserted in port P of the Plus-1 plate.

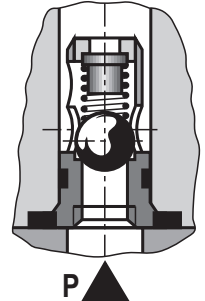

Technical data

general

Installation position		Any
Ambient temperature range	°C	-20 ... +80
Storage temperature range	°C	+5 ... +40
Maximum storage time	Years	1
Weight	3/2 directional seat valve	kg 6,2
	4/2 directional seat valve	kg 7.0
Surface protection	Valve body	Galvanized
	Solenoid	Galvanized

hydraulic

Maximum surface temperature	°C	See information on the explosion protection on page 7
Maximum operating pressure	Port P, A, B	bar 420
	Port T	bar 40
Maximum flow	l/min	12
Hydraulic fluid		See table below
Hydraulic fluid temperature range	°C	-15 ... +80
Viscosity range	mm ² /s	2.8 ... 500
Maximum admissible degree of contamination of the hydraulic fluid Cleanliness class according to ISO 4406 (c)		Class 20/18/15 ¹⁾

Hydraulic fluid	Classification	Suitable sealing materials	Standards	Data sheet
Mineral oils	HL, HLP, HLPD	NBR, FKM	DIN 51524	90220
Bio-degradable	▶ Insoluble in water	HETG	ISO 15380	90221
		HEES		
	▶ Soluble in water	HEPG	ISO 15380	

-  **Important information on hydraulic fluids:**
- ▶ For further information and data on the use of other hydraulic fluids, please refer to the data sheets above or contact us!
 - ▶ There may be limitations regarding the technical valve data (temperature, pressure range, life cycle, maintenance intervals, etc.)!
 - ▶ Ignition temperature > 180 °C

electric

Voltage type		Direct voltage
Available voltages	V	24
Voltage tolerance (nominal voltage)	%	±10
Admissible residual ripple	%	< 5
Duty cycle / operating mode according to VDE 0580		S1 (continuous operation)
Switching time according to ISO 6403 ²⁾		See page 7
Switching frequency	1/h	Up to 15000
Nominal power at ambient temperature 20 °C	W	13
Maximum power with 1.1 x nominal voltage and ambient temperature 20 °C	W	15.8
Protection class according to EN 60529		IP 65 (with correctly installed electrical connection)

¹⁾ The cleanliness classes specified for the components must be adhered to in hydraulic systems. Effective filtration prevents faults and at the same time increases the life cycle of the components.
For the selection of the filters, see www.boschrexroth.com/filter.

²⁾ The switching times were determined at a hydraulic fluid temperature of 40 °C and a viscosity of 46 cSt. Deviating hydraulic fluid temperatures can result in different switching times. Switching times change dependent on operating time and application conditions.

Technical data

Information on the explosion protection

Area of application according to directive 2014/34/EU	I M2, II 2G
Type of protection valve	c (EN 13463-5)
Maximum surface temperature ³⁾ Temperature class	°C 130 T4
Type of protection valve solenoid according to EN 60079-0 / EN 60079-1	Ex db I Mb Ex db IIC T4 Gb
Type examination certificate Solenoid	BVS 03 ATEX E 300 X
"IECEX Certificate of Conformity" solenoid	IECEX BVS 11.0091 X
Special conditions for safe use	In case of bank assembly, only one solenoid of all valves may be energized at a time.
Ambient temperature range	°C -20 ... +80

³⁾ Surface temperature > 50 °C, provide contact protection

Switching times t in ms (installation position: solenoid horizontal)

Pressure p in bar	Flow q_v in l/min	DC solenoid							
		Symbols U, C, D, Y							
		t_{On} without tank pressure				t_{Off}			
		U	C	D	Y	U	C	D	Y
70	12	35	55	40	60	20	10	25	15
140	12	35	55	40	60	25	10	30	15
280	12	35	60	40	65	30	10	35	15
320	12	35	65	40	70	30	12	35	17
420	12	35	65	40	70	35	12	40	17

Electrical connection

The type-examination tested valve solenoid of the valve is equipped with one terminal box and a type-tested cable entry.

The connection is polarity-independent.

Notice

When establishing the electrical connection, the protective earthing conductor (PE \perp) has to be connected properly.

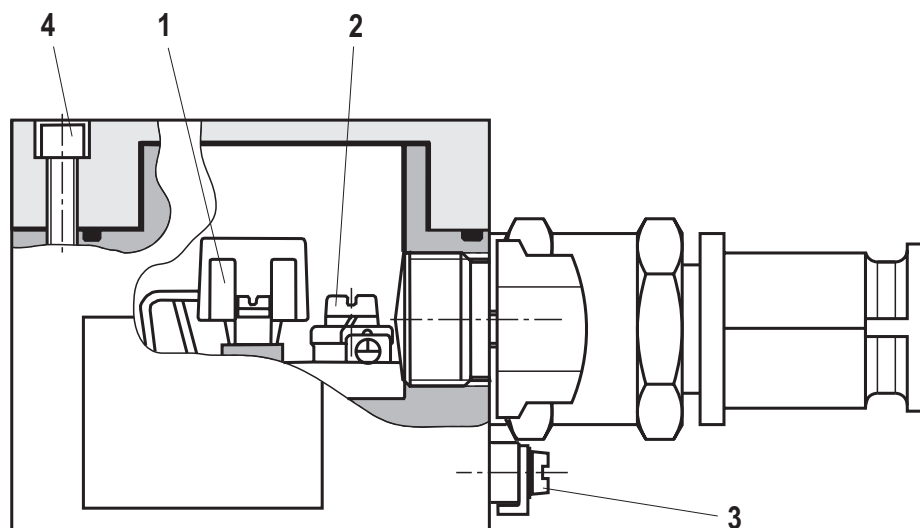

Properties of the connection terminals and mounting elements

Position	Function	Connectable line cross-section
1	Operating voltage connection	Single-wire max. 2.5 mm ² Finely stranded max. 2.5 mm ²
2	Connection for protective earthing conductor	Single-wire 0.75 ... 2.5 mm ² Finely stranded 0.75 ... 1.5 mm ²
3	Connection for potential equalization conductor	Single-wire 4 ... 6 mm ² Finely stranded min. 4 mm ²
4	Screws for cover	-

Cable gland

Line diameter	mm	9...12
Sealing		Outer sheath sealing

Connection line

Line type		Non-armored cables and lines (outer sheath sealing)
Temperature range	°C	-20 ... > +110

Electrical connection

Circuit diagram

Direct voltage, polarity-independent

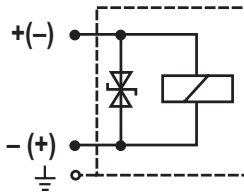

Over-current fuse and switch-off voltage peaks

Notice:

A fuse which corresponds to the rated current according to DIN 41571 and EN / IEC 60127 has to be connected upstream of every valve solenoid (max. $3 \times I_{\text{rated}}$).

The shut-off threshold of the fuse has to match the prospective short-circuit current of the supply source.

The prospective short-circuit current of the supply source may amount to a maximum of 1500 A.

This fuse may only be installed outside the potentially explosive atmosphere or must be of an explosion-proof design.

When inductivities are switched off, voltage peaks result which may cause faults in the connected control electronics.

The voltage peak must be damped by a suitable external circuitry. We recommend a circuitry with a suppressor diode with a limitation voltage of approx. 50 V.

Voltage data in the valve type code	Nominal voltage valve solenoid	Rated current valve solenoid	Recommended pre-fuse characteristics medium time-lag according to DIN 41571	Maximum voltage value upon switch-off	Interference protection circuit
G24	24 V DC	0.542 A DC	630 mA	-90 V	Suppressor diode bi-directional

General information

Seat valves can be used according to the spool symbols as well as the assigned operating pressures and flows (see performance limits on page 11).

In order to ensure safe functioning, it is absolutely necessary to observe the following:

- Seat valves have negative spool overlap, i.e. leakage oil occurs during the switching process. This process takes, however, place within such a short time that it is irrelevant in nearly all applications.
- The specified maximum flow must not be exceeded (if necessary, use a throttle insert for the flow limitation)!

Plus-1 plate:

- When the Plus-1 plate (4/2 directional function) is used, the following lower operating values have to be observed: $p_{\text{min}} = 8 \text{ bar}$, $q_V > 3 \text{ l/min}$.
- The ports P, A, B and T are clearly determined according to the tasks. They must not be exchanged or closed arbitrarily!
- Port T must always be connected.
- Pressure level and pressure distribution are to be observed!
- The flow is only admissible in the direction of arrow!

Performance limits (measured with HLP46, $\vartheta_{oil} = 40 \text{ }^\circ\text{C} \pm 5 \text{ }^\circ\text{C}$)

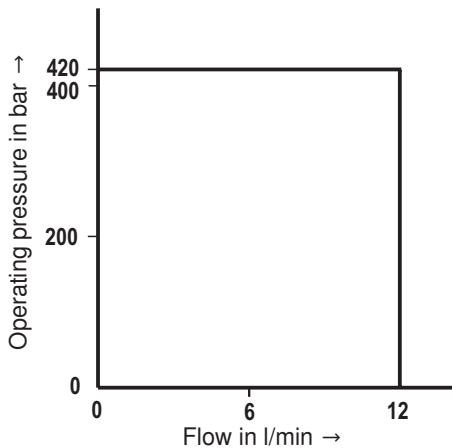

Notice:

The specified performance limits are valid for use with two directions of flow (e. g. from P → A and simultaneous return flow from B → T).

Due to the flow forces acting within the valves, the admissible switching power limit may be considerably lower with only one direction of flow (e. g. from P → A while port B is blocked)!

(In such cases, please consult us.)

The performance limits were determined when the solenoids were at operating temperature, at 10 % undervoltage and without tank preloading.

Characteristic curves (measured with HLP46, $\vartheta_{oil} = 40 \text{ }^\circ\text{C} \pm 5 \text{ }^\circ\text{C}$ and $p = 100 \text{ bar}$)

Without Plus-1 plate (M-3SE..)

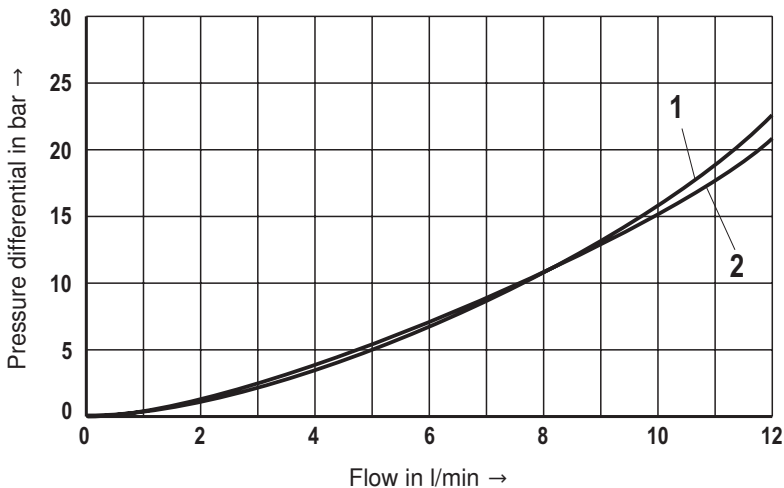

1	A-T
2	P-A

With Plus-1 plate (M-4SE..)

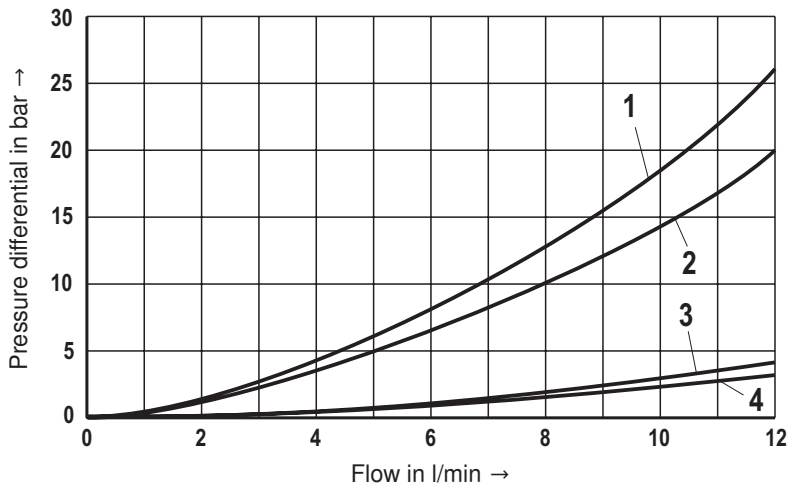

1	A-T
2	P-A
3	P-B
4	B-T

Dimensions: 3/2 directional seat valve (dimensions in mm)

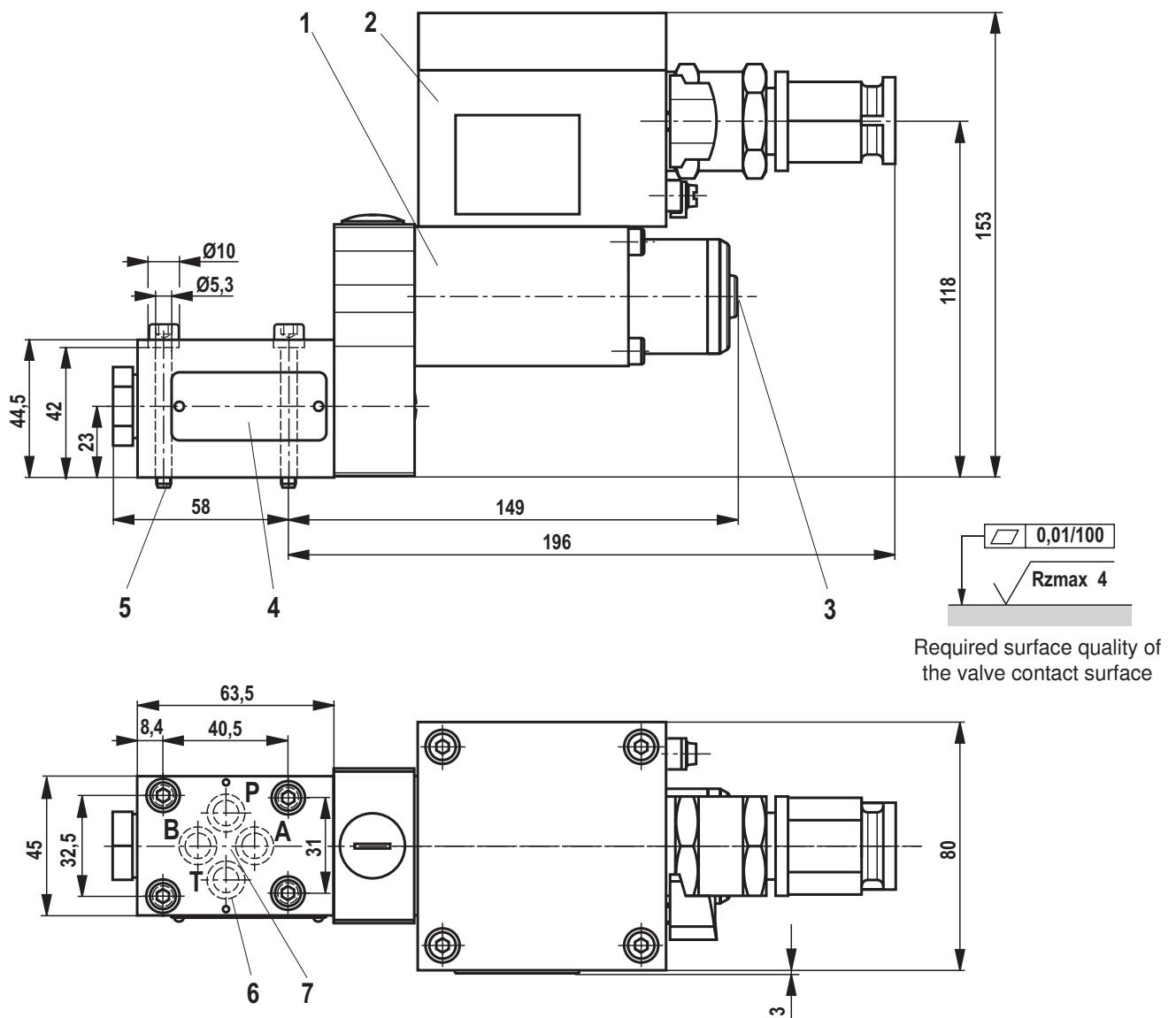

- 1 Valve solenoid
- 2 Terminal box
- 3 Manual override
- 4 Name plate
- 5 Valve mounting screws
For reasons of stability, exclusively use the following valve mounting screws:
**4 hexagon socket head cap screws
ISO 4762-M5x50-10.9-fIZn-240h-L
(friction coefficient 0.09 - 0.14 according to
VDA 235-101)**
(included in the scope of delivery)
- 6 Identical seal rings for ports P, A, B, T
- 7 Porting pattern according to ISO 4401-03-02-0-05
(but without locating hole)

Subplates (separate order) with porting pattern according to ISO 4401-03-02-0-05, see data sheet 45100.

Notice:

Subplates are no components in the sense of directive 2014/34/EU and can be used after the manufacturer of the overall system has conducted an assessment of the risk of ignition.

The "G...J3" versions are free from aluminum and/or magnesium and galvanized.

Dimensions: 4/2 directional seat valve (dimensions in mm)

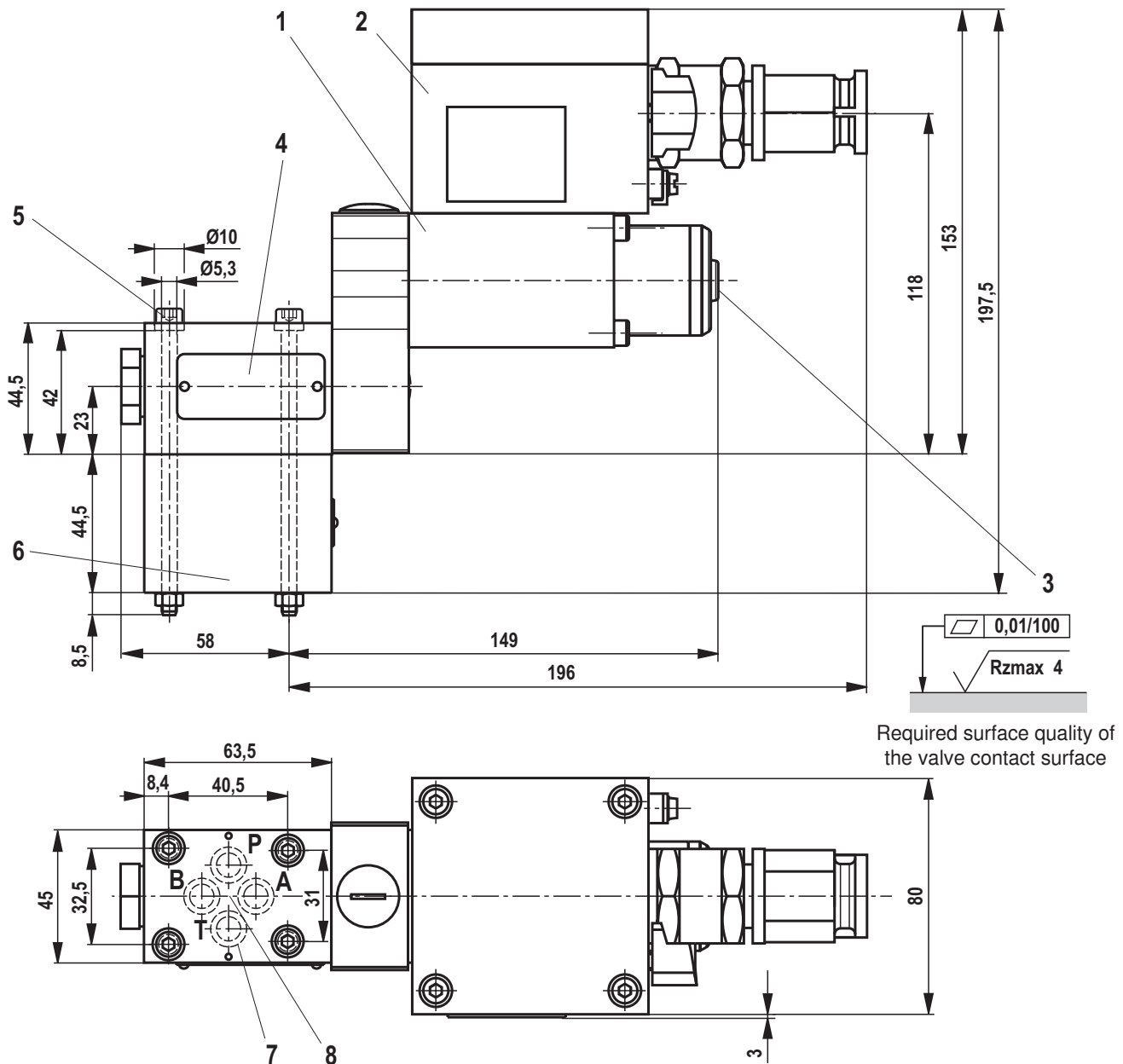

Required surface quality of the valve contact surface

- 1 Valve solenoid
- 2 Terminal box
- 3 Manual override
- 4 Name plate
- 5 Valve mounting screws
For reasons of stability, exclusively use the following valve mounting screws:
**4 hexagon socket head cap screws
ISO 4762-M5x95-10.9-flZn-240h-L
(friction coefficient 0.09 - 0.14 according to
VDA 235-101)
(included in the scope of delivery)**
- 6 Plus-1 plate
- 7 Identical seal rings for ports P, A, B, T
- 8 Porting pattern according to ISO 4401-03-02-0-05
(but without locating hole)

Subplates (separate order) with porting pattern according to ISO 4401-03-02-0-05, see data sheet 45100.

Notice:

Subplates are no components in the sense of directive 2014/34/EU and can be used after the manufacturer of the overall system has conducted an assessment of the risk of ignition.

The "G...J3" versions are free from aluminum and/or magnesium and galvanized.

Installation conditions (dimensions in mm)

	Individual assembly	Bank assembly
Subplate dimensions	Minimum dimensions Length ≥ 64 , width ≥ 58 , height ≥ 25	Minimum cross-section Height ≥ 60 , width ≥ 85
Thermal conductivity of the subplate	≥ 38 W/mK (EN-GJS-500-7)	
Minimum distance between the longitudinal valve axes	See schematic diagram below	

Schematic diagram

Individual assembly

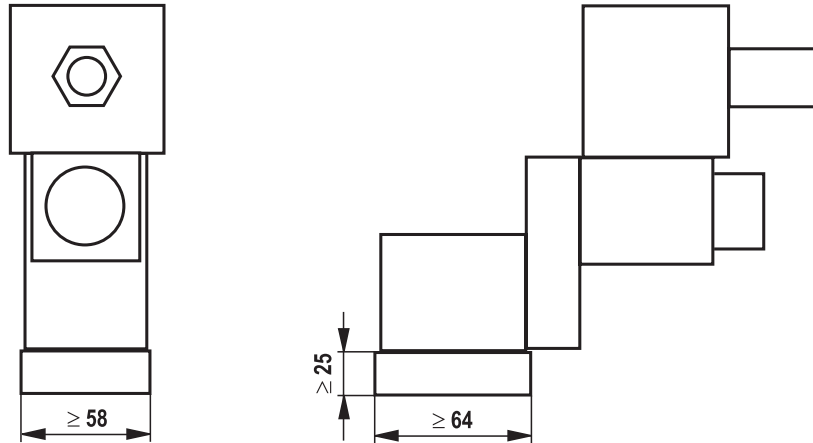

Bank assembly

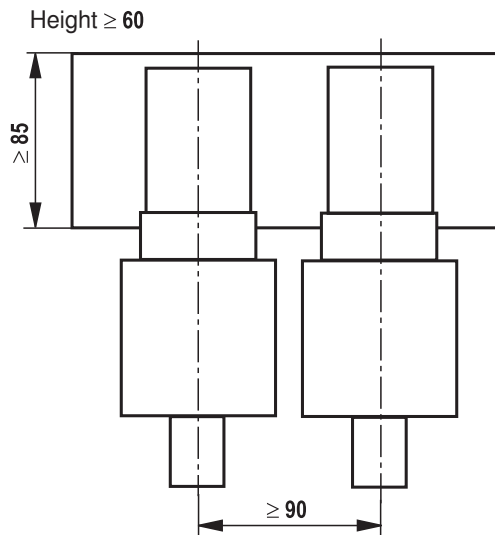

Notice:

In case of bank assembly, only one solenoid of all valves may be energized at a time.

Further information

Subplates

Use of non-electrical hydraulic components in an explosive environment (ATEX)

Hydraulic fluids on mineral oil basis

Environmentally compatible hydraulic fluids

Directional seat valves, direct operated, with solenoid actuation

Selection of filters

Information on available spare parts

Data sheet 45100

Data sheet 07011

Data sheet 90220

Data sheet 90221

Operating instructions 22047-XD-B

www.boschrexroth.com/filter

www.boschrexroth.com/spc

Notes

Notes
