

# Directional spool valves, pilot-operated, with hydraulic or electro-hydraulic actuation

## WEH and WH

**RE 24751**

Edition: 2018-12

Replaces: 2016-06



H8051+8052

- ▶ Size 10 ... 32
- ▶ Component series 4X; 6X; 7X
- ▶ Maximum operating pressure 350bar [5076psi]
- ▶ Maximum flow 1100 l/min [290 US gpm]

### Features

- ▶ 4/3-, 4/2- or 3/2-way version
- ▶ Types of actuation (internal or external pilot control):
  - Electro-hydraulic (type WEH)
  - Hydraulic (type WH)
- ▶ For subplate mounting
- ▶ Porting pattern according to ISO 4401 and NFPA T3.5.1 R2
- ▶ Spring or pressure centering, spring end position or hydraulic end position
- ▶ Wet-pin DC or AC solenoids, optional
- ▶ Electrical connection as individual or central connection
- ▶ Optional versions:
  - Manual override
  - Switching time adjustment
  - Preload valve in channel P of the main valve
  - Stroke setting and/or spool position monitoring

### Contents

Features	1
Ordering code	2 ... 4
Symbols	5 ... 9
Function, section	10 ... 12
Pilot oil supply	13 ... 14
Technical data	15 ... 18
Characteristic curves, performance limits	19 ... 28
Dimensions	29 ... 35
Stroke setting, mounting options	36, 37
Switching time adjustment	38
Pressure reducing valve "D3"	38
Preload valve	39
Project planning information	40
Further information	40

## Ordering code

01	02	03	04	05	06	07	08	09	10	11	12	13	14	15	16	17	18	19	20	21	22
						/									/						*

01	Up to 280 bar	<b>no code</b>
	Up to 350 bar	<b>H -</b>
02	3-way version	<b>3</b>
	4-way version	<b>4</b>

### Types of actuation

03	Electro-hydraulic	<b>WEH</b>
	Hydraulic	<b>WH</b>

### Size

04	NG10	<b>10</b>
	NG16	<b>16</b>
	NG25 (version "W.H 22")	<b>22</b>
	NG25 (version "W.H 25")	<b>25</b>
	NG32	<b>32</b>

### Spool return in the main valve

05	By means of springs	<b>no code</b>
	Hydraulic <sup>1)</sup>	<b>H</b>
06	For symbols, see page 5 and 6	
07	Component series 40 ... 49 (40 ... 49: unchanged installation and connection dimension) – NG10	<b>4X</b>
	Component series 60 ... 69 (60 ... 69: unchanged installation and connection dimension) – NG25 ("W.H 25") and NG32	<b>6X</b>
	Component series 70 ... 79 (70 ... 79: unchanged installation and connection dimension) – NG16 (from series 72) and NG25 ("W.H 22")	<b>7X</b>

**Control spool return in the pilot control valve** with 2 spool positions and 2 solenoids  
(only possible with symbols C, D, K, Z and hydraulic control spool return in the main valve)

08	<b>With</b> spring return	<b>no code</b>
	<b>Without</b> spring return	<b>O</b>
	<b>Without</b> spring return with detent <sup>2)</sup>	<b>OF</b>

### Pilot control valve <sup>(2)</sup>

09	High-power valve (data sheet 23178)	<b>6E</b>
10	Direct voltage 24 V <sup>2)</sup>	<b>G24</b>
	Alternating voltage 230 V 50/60 Hz <sup>2)</sup>	<b>W230</b>
	For other voltages, frequencies and electric data, see data sheet 23178	
11	<b>Without</b> manual override	<b>no code</b>
	<b>With</b> manual override	<b>N</b>
	<b>With</b> concealed manual override	<b>N9</b>

### Pilot oil flow

12	External pilot oil supply, external pilot oil return <sup>3)</sup>	<b>no code</b>
	Internal pilot oil supply, external pilot oil return <sup>3); 4)</sup>	<b>E</b>
	Internal pilot oil supply, internal pilot oil return <sup>4)</sup>	<b>ET</b>
	External pilot oil supply, internal pilot oil return <sup>3)</sup>	<b>T</b>
(For type WH... <b>only "no code"</b> ; version "ET" and "T" with 3-spool position valve, pressure-centered <b>only</b> possible if $p_{pilot} \geq 2 \times p_{tank} + p_{pilot\ min!}$ )		

## Ordering code

01	02	03	04	05	06	07	08	09	10	11	12	13	14	15	16	17	18	19	20	21	22	
							/									/						*

### Switching time adjustment

13	<b>Without</b> switching time adjustment	no code
	Switching time adjustment as supply control	S
	Switching time adjustment as discharge control	S2

### Corrosion resistance (outside)

14	None (valve housing primed)	no code
	Improved corrosion protection (240 h salt spray test according to EN ISO 9227)	J3

### Electrical connection <sup>2)</sup>

15	<b>Individual connection</b>	
	<b>Without</b> mating connector; connector DIN EN 175301-803	K4 <sup>6)</sup>
	For further electrical connections, see data sheet 23178 and 08010	

### Spool position monitoring

16	<b>Without</b> position switch	no code
	Monitored spool position "a"	QMAG24
	Monitored spool position "b"	QMBG24
	Monitored spool position "a" and "b"	QMABG24
	Monitored rest position	QM0G24
For more information, see data sheet 24830		

### Stroke setting

17	For ordering code, see page 36 and 37	
----	---------------------------------------	--

### Throttle insert <sup>2)</sup>

18	<b>Without</b> throttle insert	no code
	Throttle Ø 0.8 mm [0.0315 inch]	B08
	Throttle Ø 1.0 mm [0.0394 inch]	B10
	Throttle Ø 1.2 mm [0.0472 inch]	B12
	Throttle Ø 1.5 mm [0.0591 inch]	B15
	Throttle Ø 2.0 mm [0.0787 inch]	B20
	Throttle Ø 2.5 mm [0.0984 inch]	B25

### Preload valve (not for NG10) <sup>2)</sup>

19	<b>Without</b> preload valve	no code
	<b>With</b> preload valve ( $p_c = 4.5 \text{ bar [65 psi]}$ )	P4,5
20	<b>Without</b> pressure reducing valve	no code
	<b>With</b> pressure reducing valve	D3 <sup>5)</sup>

### Seal material (Observe compatibility of seals with hydraulic fluid used, see page xx)

21	NBR seals	no code
	FKM seals	V
	Observe compatibility of seals with hydraulic fluid used. (other seals on request)	
22	For further information, see the plain text	*

$p_{\text{pilot}}$  = pilot pressure  
 $p_{\text{pilot min}}$  = minimum pilot pressure  
 $p_{\text{tank}}$  = tank pressure  
 $p_c$  = cracking pressure

Explanation of the footnotes, see page 4.

## Ordering code

- 1) ▶ 2 spool positions (hydraulic end position): only symbols C, D, K, Z, Y
  - ▶ 3 switching positions (hydraulically centered): only NG16, NG25 ("4W.H 25") and NG32
- 2) Only with electro-hydraulic actuation (type WEH)
- 3) Pilot oil supply X or return Y **external**:
  - ▶ The maximum admissible operating parameters of the pilot control valve must be observed (see data sheet 23178)!
  - ▶ Minimum pilot pressure: please observe page 16!
  - ▶ Maximum pilot pressure: please observe page 16!
- 4) Pilot oil supply **internal** (version "ET" and "E"):
  - ▶ Minimum pilot pressure: please observe page 16!
  - ▶ Maximum pilot pressure: please observe page 16!  
With a higher pilot pressure, use of a **pressure reducing valve "D3"** is required (if it is not used pilot pressure = operating pressure at the port!).
  - ▶ In order to prevent inadmissibly high pressure peaks, a **"B10" throttle insert** has to be provided in port P of the pilot control valve (see page 14).
  - ▶ In connection with version "H", the **pressure reducing valve "D3"** is also required.
- 5) Only in connection with the **"B10"** throttle insert
- 6) Mating connectors, separate order, see data sheet 23178

**Symbols:** 2 spool positions

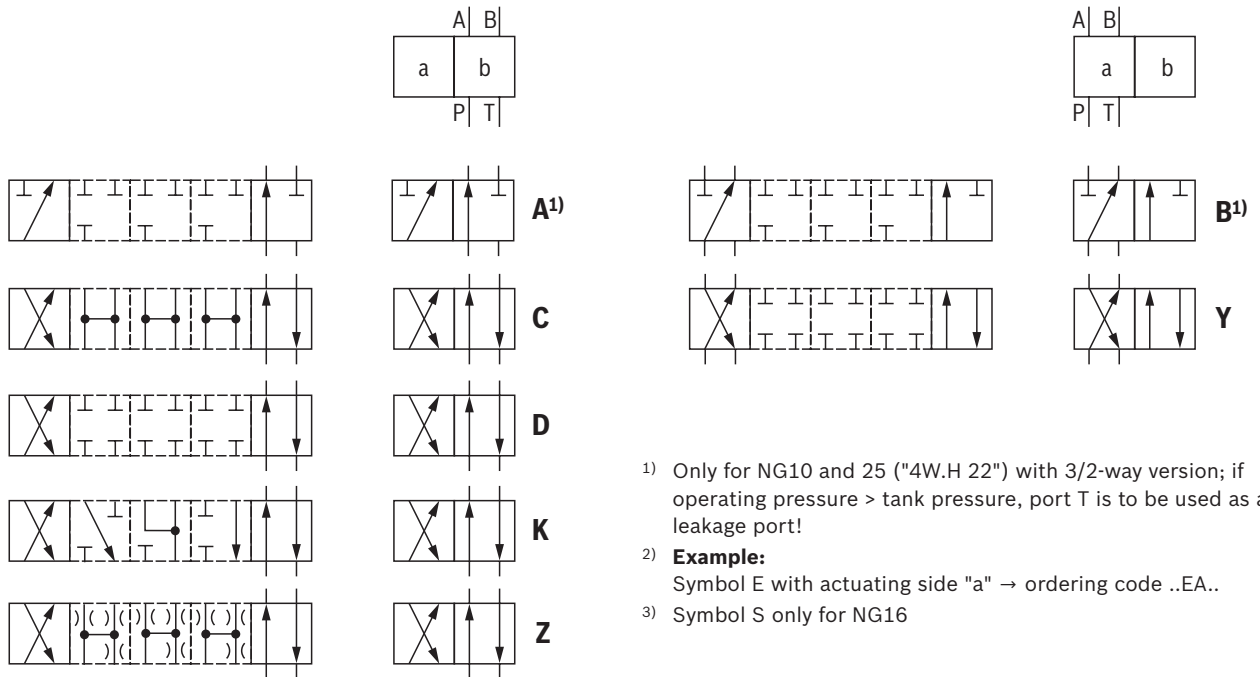

- 1) Only for NG10 and 25 ("4W.H 22") with 3/2-way version; if operating pressure > tank pressure, port T is to be used as a leakage port!
- 2) **Example:**  
Symbol E with actuating side "a" → ordering code ..EA..
- 3) Symbol S only for NG16

Ordering code		Type of actuation	
Symbol	Spool return	Type WH (hydraulic)	Type WEH (electro-hydraulic)
A <sup>1)</sup> , C, D, K, Z	../..		
	..H../..		
	..H../O		
	..H../OF		
B <sup>1)</sup> , Y	../..		
	..H../..		

**Symbols:** 3 spool positions

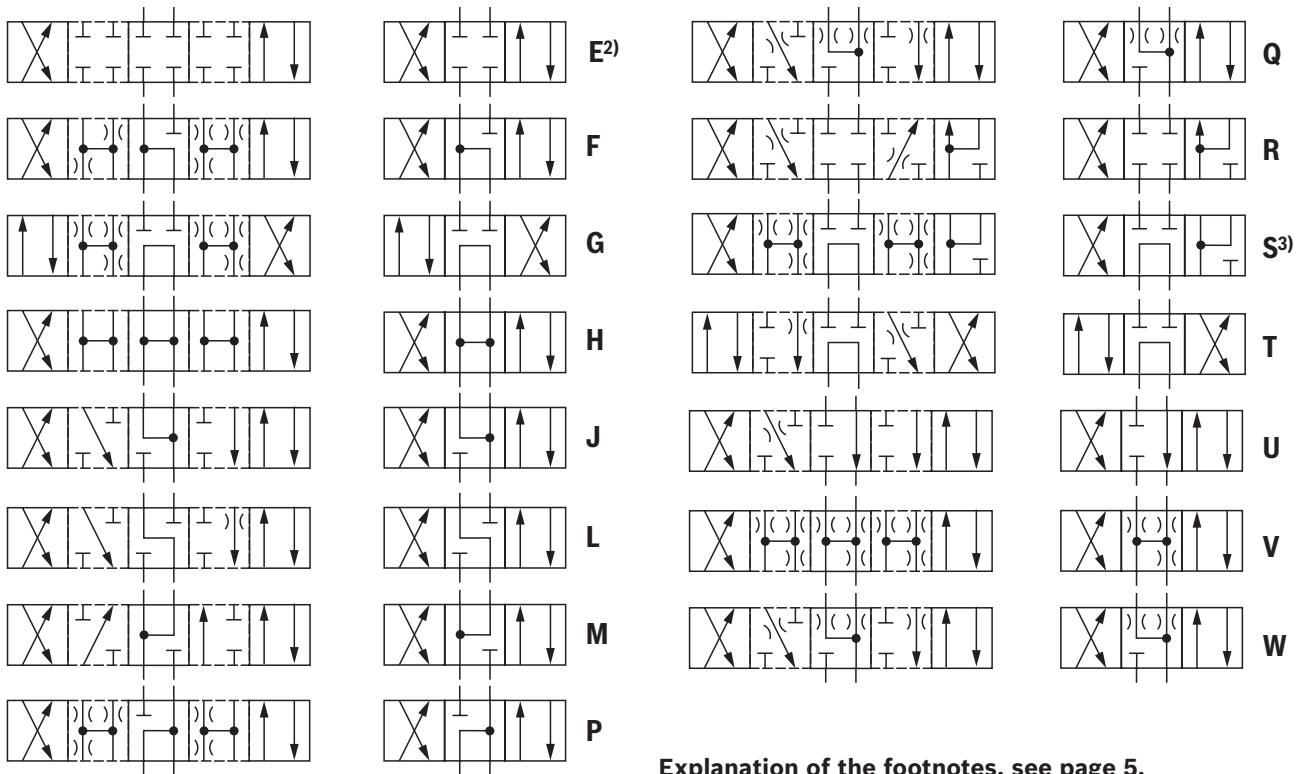

Explanation of the footnotes, see page 5.

Symbol	Ordering code		Type of actuation		
	Actuating side	Spool return	Type WH (hydraulic)	Type WEH (electro-hydraulic)	
E, F, G, H, J, L, M, P, Q, R, S, T, U, V, W		../..			
	.A				
	.B				
		..H../..			
		H.A			
		H.B			

Symbols for valves with 2 spool positions

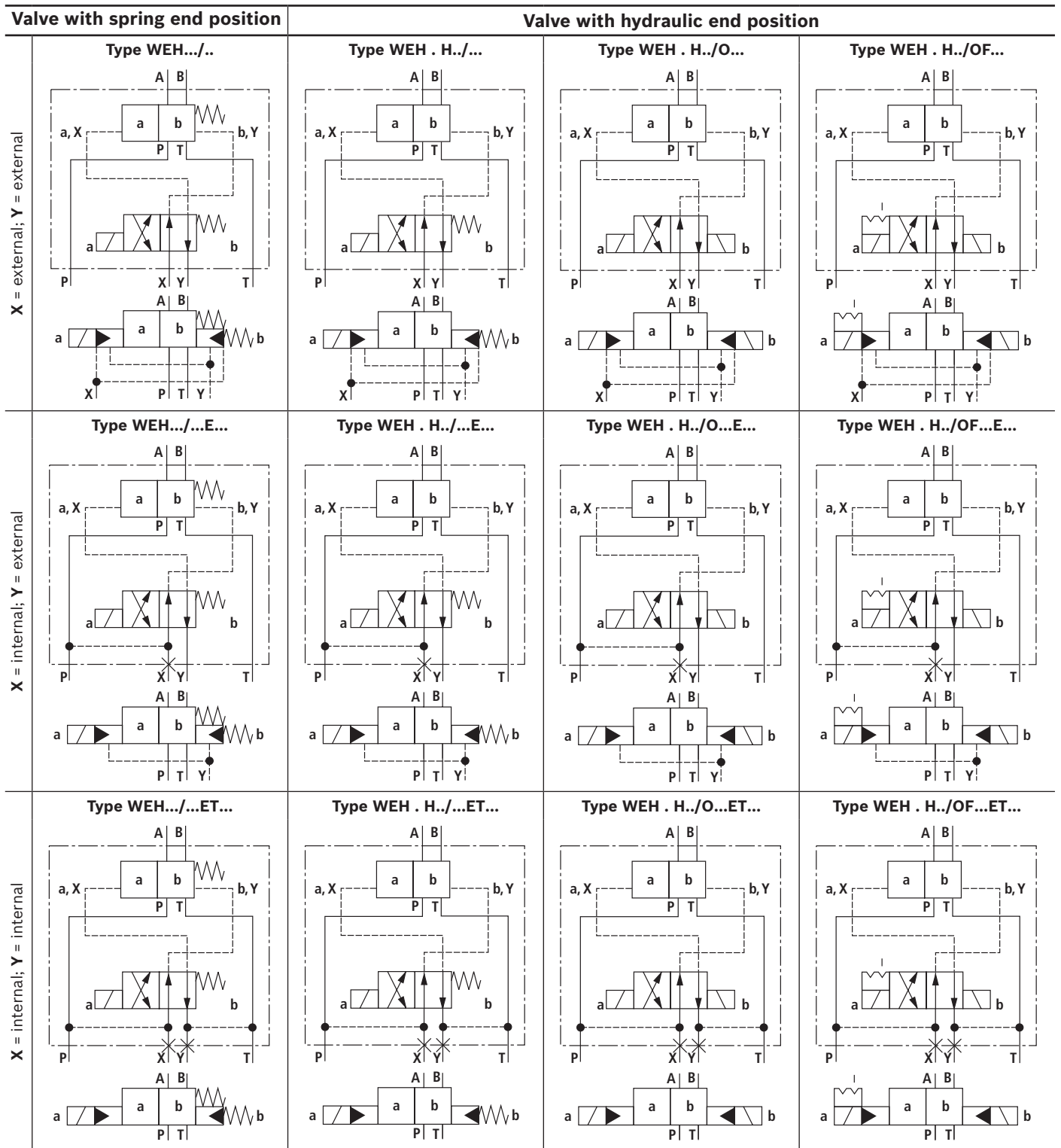

### Symbols for valves with 2 spool positions

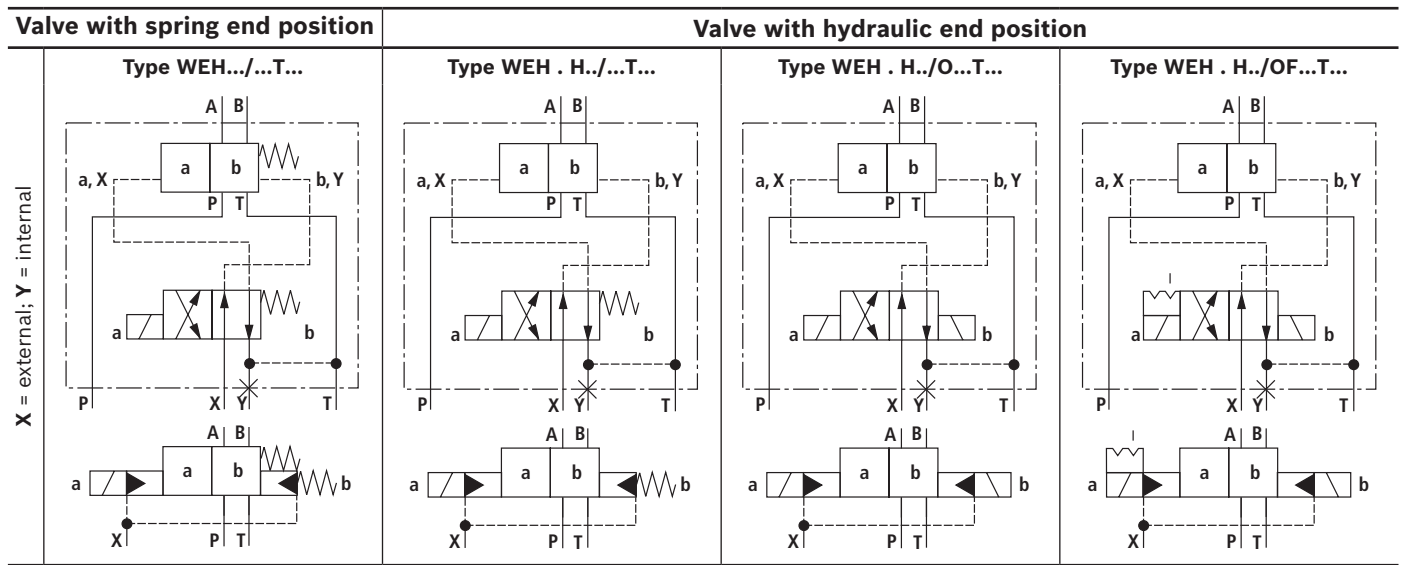

### Symbols for valves with 3 spool positions

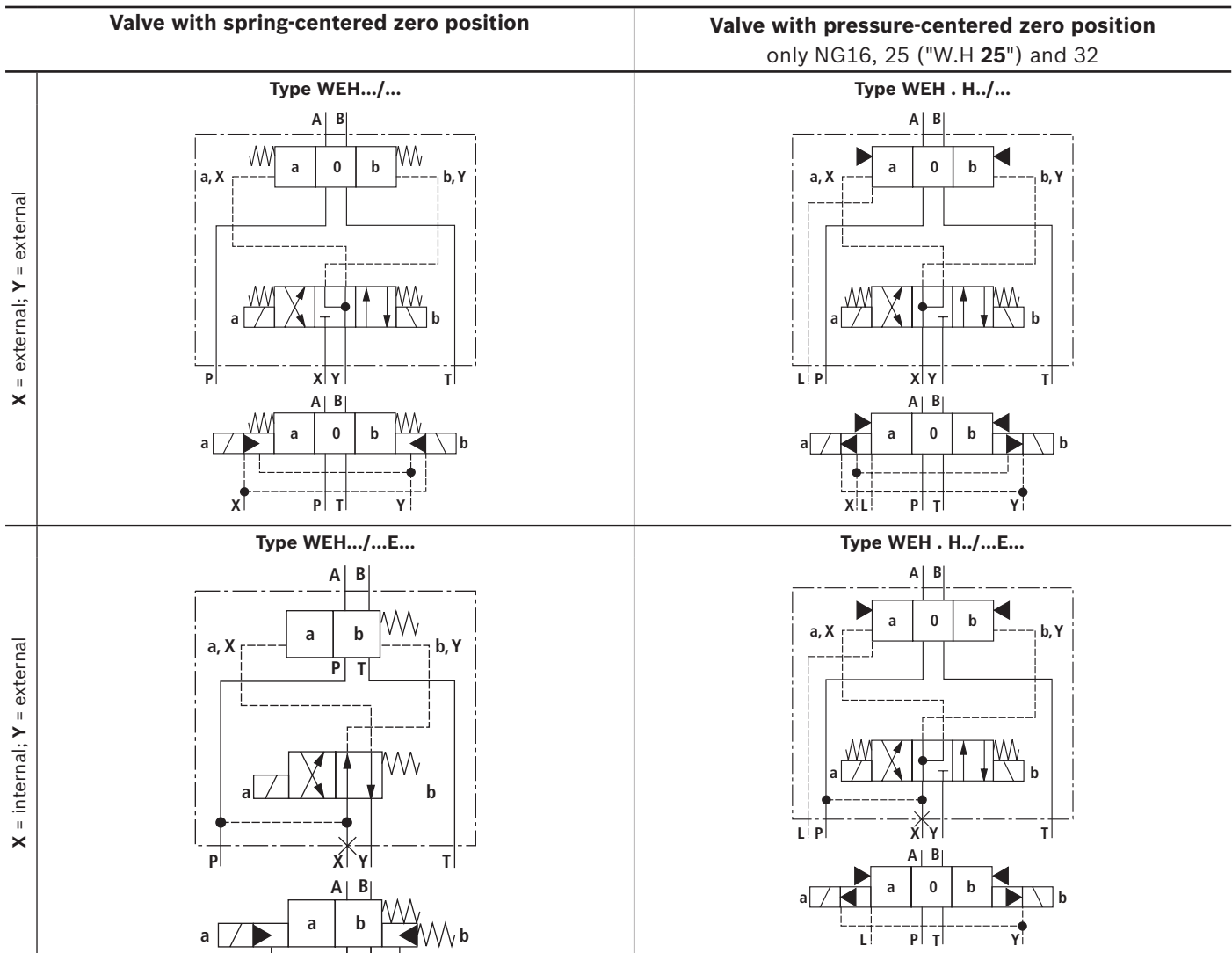



### Symbols for valves with 3 spool positions

	Valve with spring-centered zero position	Valve with pressure-centered zero position only NG16, 25 ("W.H 25") and 32
X = internal; Y = internal	<p style="text-align: center;"><b>Type WEH.../...ET...</b></p>	<p style="text-align: center;"><b>Type WEH . H./...ET...</b></p>
X = external; Y = internal	<p style="text-align: center;"><b>Type WEH.../...T...</b></p>	<p style="text-align: center;"><b>Type WEH . H./...T...</b></p>

**Notice:**  
 3-spool position valves, pressure-centered, preferably with external pilot oil supply and/or return ("no code", "E")  
 For preconditions for internal pilot oil supply and/or return ("ET", "T"), see page 4 and 15.

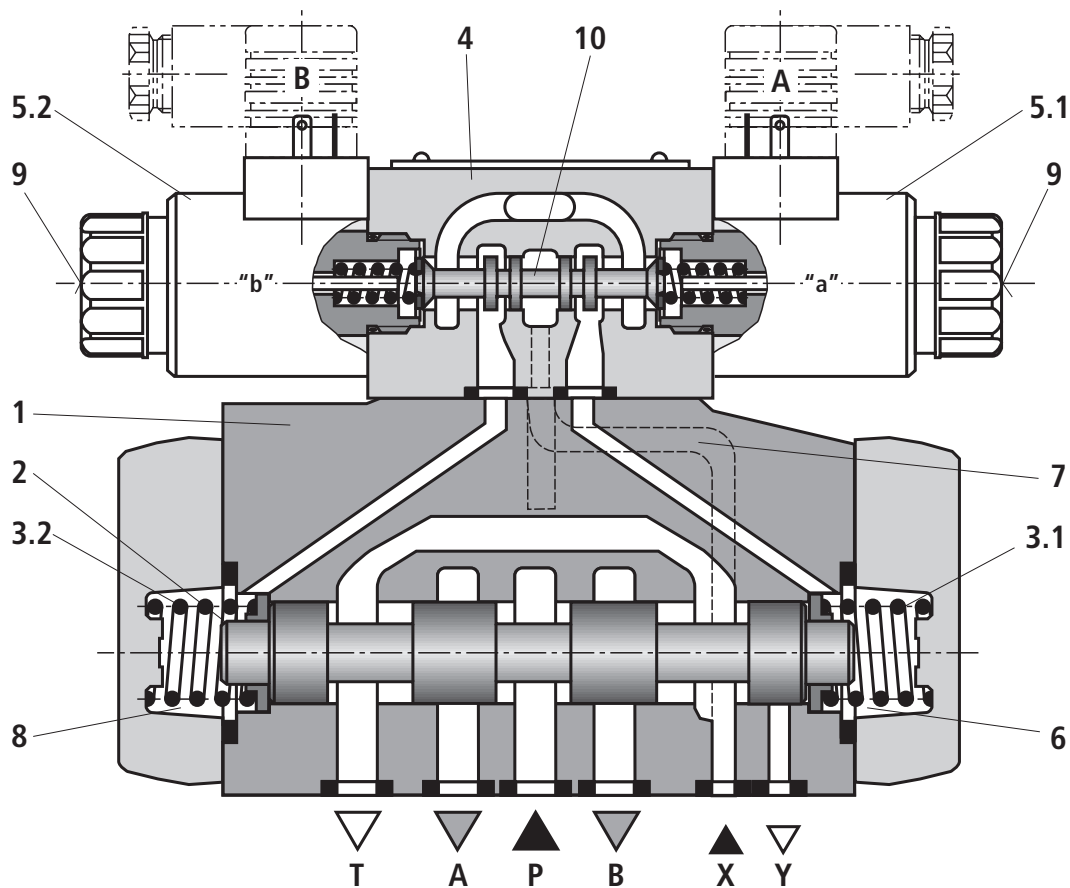
**Function, section: Type WEH****Directional valves type WEH...**

The valve type WEH is a directional spool valve with electro-hydraulic actuation. It controls the start, stop and direction of a flow.

The directional valve basically consists of the main valve with housing (1), the main control spool (2), one or two return springs (3.1) and (3.2), as well as the pilot control valve (4) with one or two solenoids "a" (5.1) and/or "b" (5.2).

The main control spool (2) in the main valve is held in the zero or initial position by the springs or by means of pressurization. In the initial position, the two spring chambers (6) and (8) are connected with the tank in a depressurized form via the pilot control valve (4). Via the control line (7), the pilot control valve is supplied with pilot oil. Supply can be implemented internally or externally (externally via port X). Upon actuation of the pilot control valve, e.g. solenoid "a", the pilot control spool (10) is moved to the left and thus, the spring chamber (8) is pressurized with pilot pressure. The spring chamber (6) remains depressurized.

The pilot pressure acts on the left side of the main control spool (2) and moves it against the spring (3.1). This connects port P with B and A with T in the main valve.

On switching off of solenoid, the pilot control spool (10) returns to its initial position (except impulse spool). The spring chamber (8) is unloaded to the tank.

The pilot oil return is implemented internally (via channel T) or externally (via channel Y).

An optional manual override (9) allows for moving of the pilot control spool (10) without solenoid energization.

**Notices:**

The return springs (3.1) and (3.2) in the spring chambers (6) and (8) hold the main control spool (2) in central position without pilot pressure even with, for example, vertical valve positioning.

**Due to the design principle, internal leakage is inherent to the valves, which may increase over the life cycle.**

**For pilot oil supply, see page 13 and 14.**

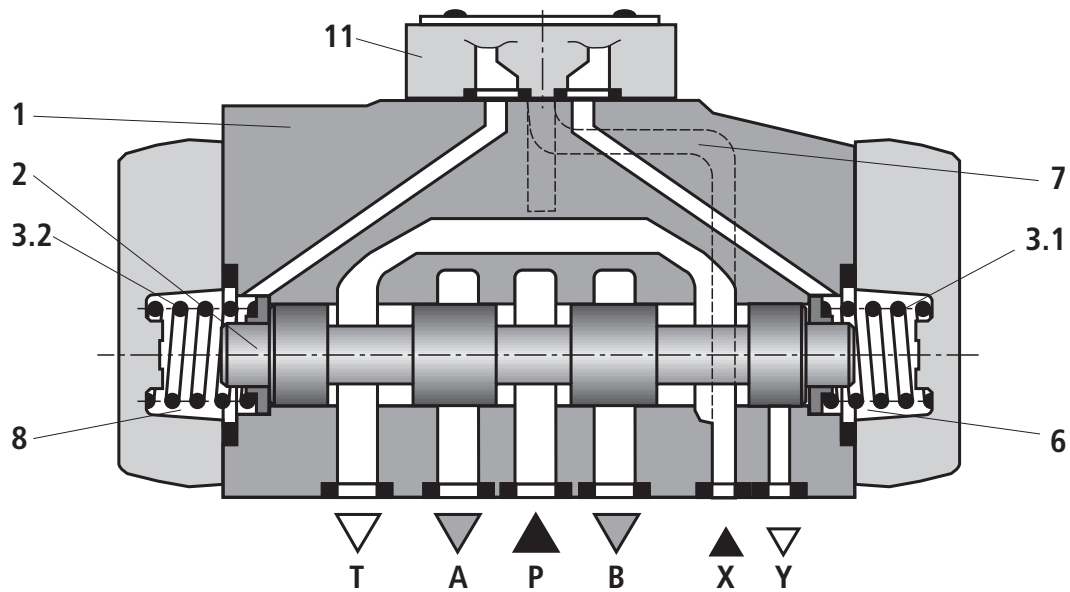
**Function, section: Type WH****Directional valves type WH...**

Valve type WH is a directional spool valve with hydraulic actuation. It controls the start, stop and direction of a flow.

The directional valve basically consists of the valve housing (1), the main control spool (2), one or two return springs (3.1) and (3.2) at valves with spring return or spring centering as well as the diversion plate (11).

The main control spool (2) is actuated directly by pressurization.

The main control spool (2) is held in zero or initial position by springs or pressurization. Pilot oil supply and return are external (see page 13).

**4/3 directional valve with spring centering of the control spool**

With this version, the main control spool (2) is held in zero position by two return springs (3.1) and (3.2). The two spring chambers (6) and (8) are connected to ports X and Y via the diversion plate (11).

With pilot pressure loading of one of the two front sides of the main control spool (2), the spool is moved to the switching position. In the valve, the required ports are connected in this way.

The spring on the opposite side returns the spool to the zero or initial position at pressure relief of the pressurized control spool area.

**For pilot oil supply, see page 13 and 14.**



**Pilot oil supply** (schematic illustration)

**NG10**

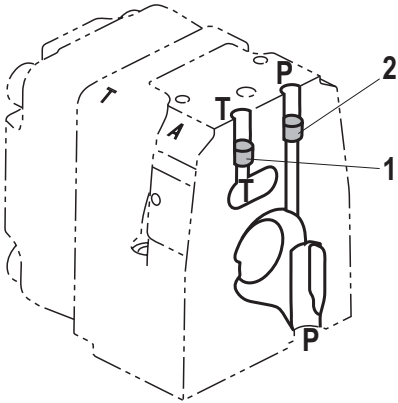

**NG16**

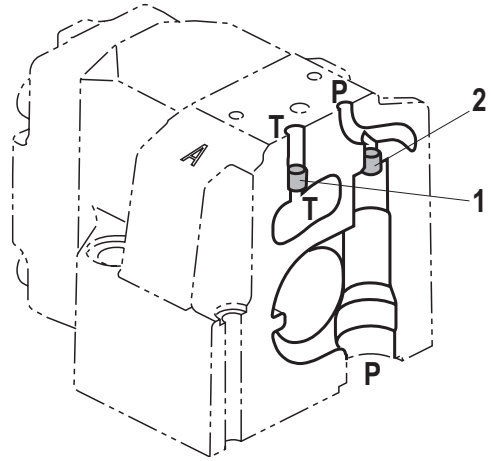

**NG25 ("W.H 22")**

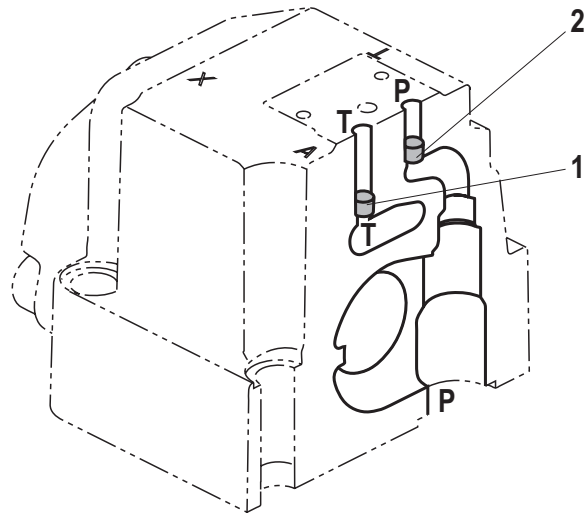

**NG25 ("W.H 25")**

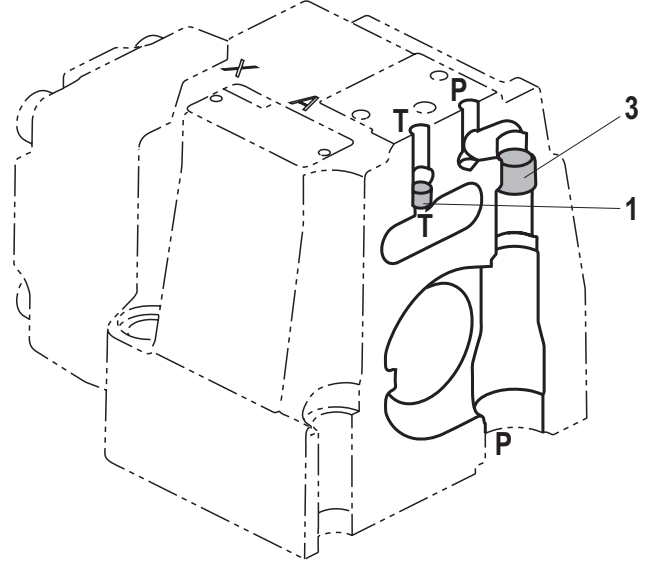

**NG32**

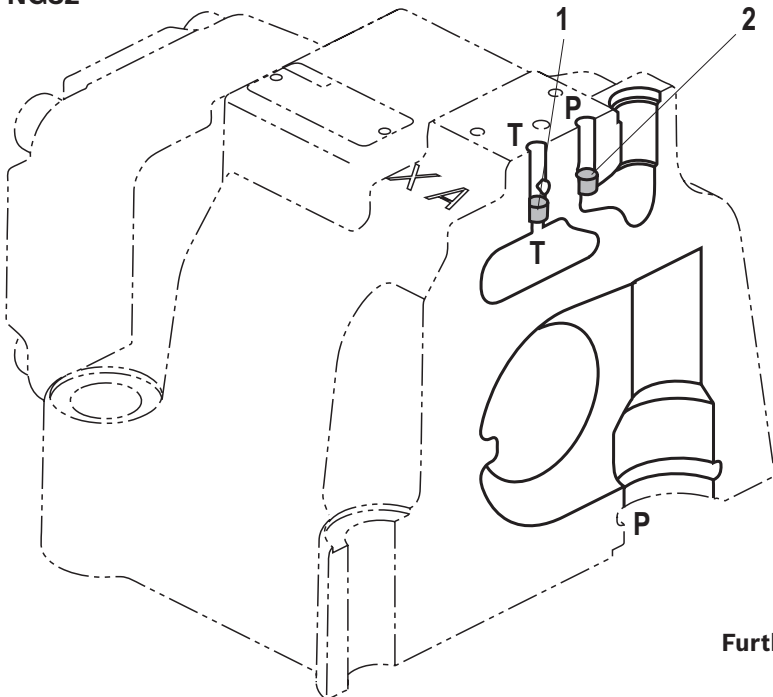

- 1 Plug screw M6 according to DIN 906, wrench size 3 – pilot oil return
- 2 Plug screw M6 according to DIN 906, wrench size 3 – pilot oil supply
- 3 Plug screw M12 x 1.5 according DIN 906, wrench size 6 – pilot oil supply

**Pilot oil supply**

external: 2, 3 closed  
 internal: 2, 3 open

**Pilot oil return**

external: 1 closed  
 internal: 1 open

**Further explanations on page 14.**

## Pilot oil supply

### Type WH...

The pilot oil supply and return is implemented **externally** via channel X and Y.

### Type WEH...

The pilot oil supply is implemented **externally** - via channel X - from a separate pressure supply.

The pilot oil return is implemented **externally** - via channel Y - into the tank.

### Type WEH...E...

The pilot oil supply is implemented **internally** from channel P of the main valve. (see page 15, footnotes <sup>5)</sup> and <sup>6)</sup>)

The pilot oil return is implemented **externally** - via channel Y - into the tank. In the subplate, port X is closed.

### Type WEH...ET...

The pilot oil supply is implemented **internally** from channel P of the main valve.

The pilot oil return is implemented **internally** - via channel T - into the tank. In the subplate, ports X and Y are closed.

### Type WEH...T...

The pilot oil supply is implemented **externally** - via channel X - from a separate pressure supply.

The pilot oil return is implemented **internally** - via channel T - into the tank. In the subplate, port Y is closed.

### Throttle insert

Use of the throttle insert (5) is necessary if the pilot oil supply in channel P of the pilot control valve is to be limited (see below).

The throttle insert (5) is inserted in channel P of the pilot control valve.

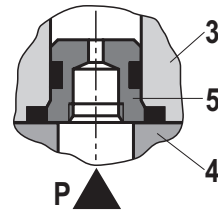

#### Notices:

**The modification of the pilot oil supply may only be performed by authorized specialists or at the factory!**

- ▶ Pilot oil supply X or return Y **external**:
  - The maximum admissible operating parameters of the pilot control valve must be observed (see data sheet 23178)!
  - Maximum pilot pressure: please observe page 16!
- ▶ Pilot oil supply **internal** (version "ET" and "E"):
  - Minimum pilot pressure: please observe page 15!
  - In order to prevent inadmissibly high pressure peaks, a **"B10" throttle insert** has to be provided in port P of the pilot control valve (see above).
  - In connection with version "H", the **pressure reducing valve "D3"** (see page 38) is also required.

- 3 Pilot control valve
- 4 Main valve
- 5 Throttle insert

**Technical data**

(For application outside these values, please consult us!)

<b>general</b>							
Sizes	NG	10	16	25 "W.H 22"	25 "W.H 25"	32	
Weight, approx.	▶ Valve with one solenoid	kg [lbs]	6.4 [14.1]	8.5 [18.7]	11.5 [25.3]	17.6 [38.8]	17.6 [38.8]
	▶ Valve with two solenoids, spring-centered	kg [lbs]	6.8 [15.0]	8.9 [19.6]	11.9 [26.2]	19.0 [41.9]	41.0 [90.4]
	▶ Valve with two solenoids, pressure-centered	kg [lbs]	6.8 [15.0]	8.9 [19.6]	11.9 [26.2]	19.0 [41.9]	41.0 [90.4]
	▶ Valve with hydraulic actuation (type WH...)	kg [lbs]	5.5 [12.1]	7.3 [16.1]	10.5 [23.1]	16.5 [36.4]	39.5 [87.1]
	▶ Switching time adjustment "S" and "S2"	kg [lbs]	0.8 [1.8]	0.8 [1.8]	0.8 [1.8]	0.8 [1.8]	0.8 [1.8]
	▶ Pressure reducing valve "D3"	kg [lbs]	0.4 [0.9]	0.4 [0.9]	0.4 [0.9]	0.4 [0.9]	0.4 [0.9]
Installation position	Any; horizontal with valves with hydraulic control spool return "H" and symbol A, B, C, D, K, Z, Y. With suspended installation, higher sensitivity to contamination – horizontal is recommended.						
Ambient temperature range	▶ Standard version	°C [°F]	-20 ... +50 [-4 ... +122] (NBR seals) -15 ... +70 [+5 ... +122] (FKM seals)				
	▶ Version for HFC hydraulic fluid	°C [°F]	-20 ... +50 [-4 ... +122]				
Storage temperature range		°C [°F]	+5 ... +40 [+41 ... +104]				
Surface protection (valve body)	Coating, layer thickness max. 100 µm						
MTTF <sub>d</sub> values according to EN ISO 13849	Years	100 (type WEH), 150 (type WH) (for further details, see data sheet 08012)					

<b>hydraulic</b>								
Maximum operating pressure								
▶ Port P, A, B	Type W.H	bar [psi]	280 [4061]	280 [4061]	280 [4061]	280 [4061]	280 [4061]	
	Type H-W.H	bar [psi]	350 [5076]	350 [5076]	350 [5076]	350 [5076]	350 [5076]	
▶ Port T	External pilot oil return Y	Type W.H	bar [psi]	280 [4061]	250 [3626]	250 [3626]	250 [3626]	250 [3626]
		Type H-W.H		315 [4568]	250 [3626]	250 [3626]	250 [3626]	250 [3626]
	Internal pilot oil return Y <sup>1)</sup>	Type H-WEH, WEH	bar [psi]	210 [3046] with direct voltage 160 [2320] with alternating voltage				
▶ Port Y	External pilot oil return	Type H-WEH, WEH	bar [psi]	210 [3046] with direct voltage 160 [2320] with alternating voltage				
		Type WH, H-WH	bar [psi]	250 [3626]	250 [3626]	210 [3046]	250 [3626]	250 [3626]
Hydraulic fluid	see table on page 15							
Hydraulic fluid temperature range (at the valve working ports) <sup>3)</sup>		°C [°F]	-20 ... +80 [-4 ... +176] (NBR seals) -15 ... +80 [+5 ... +176] (FKM seals) -20 ... +50 [-4 ... +122] (HFC hydraulic fluid)					
Viscosity range		mm <sup>2</sup> /s [SUS]	2.8 ... 500 [35 ... 2320]					
Maximum admissible degree of contamination of the hydraulic fluid Cleanliness class according to ISO 4406 (c)	Class 20/18/15 <sup>2)</sup>							

<sup>1)</sup> As a 3-spool position valve, pressure-centered only possible if

$$p_{\text{pilot}} \geq 2 \times p_{\text{tank}} + p_{\text{pilot min}}$$

<sup>2)</sup> The cleanliness classes specified for the components must be adhered to in hydraulic systems. Effective filtration prevents faults and simultaneously increases the life cycle of the components.

For selecting the filters, see [www.boschrexroth.com/filter](http://www.boschrexroth.com/filter).

<sup>3)</sup> If type WH is used in potentially explosion-proof areas, see data sheet 07011.

**Technical data**

(For applications outside these parameters, please consult us!)

<b>hydraulic</b>							
Size	NG	10	16	25	25	32	
				"W.H 22"	"W.H 25"		
Maximum pilot pressure <sup>4)</sup>	bar [psi]	250 [3626]	250 [3626]	210 [3046]	250 [3626]	250 [3626]	
Minimum pilot pressure							
▶ External pilot oil supply X (all symbols), internal pilot oil supply (only symbols D, K, E, J, L, M, Q, R, U, W)							
3-spool position valve, spring-centered	Type H-W.H...	bar [psi]	12 [174]	14 [203]	12.5 [181]	13 [188]	8.5 [123]
	Type W.H...	bar [psi]	12 [174]	14 [203]	10.5 [152]	13 [188]	8.5 [123]
3-spool position valve, pressure-centered		bar [psi]	–	14 [203]	–	18 [261]	8.5 [123]
2-spool position valve with spring end position	Type H-W.H...	bar [psi]	10 [145]	14 [203]	14 [203]	13 [188]	10 [145]
	Type W.H...	bar [psi]	10 [145]	14 [203]	11 [159]	13 [188]	10 [145]
2-spool position valve with hydraulic end position		bar [psi]	7 [101]	14 [203]	8 [116]	8 [116]	5 [72]
▶ Internal pilot oil supply X (only type WEH) (with symbols C, F, G, H, P, T, V, Z, S <sup>5)</sup> )		bar [psi]	7.5 [109] 6)	4.5 [65] <sup>7)</sup>	4.5 [65] <sup>7)</sup>	4.5 [65] <sup>7)</sup>	4.5 [65] <sup>7)</sup>
Free flow cross-sections in zero position with symbols Q, V and W							
Symbol <b>Q</b>	A – T; B – T	mm <sup>2</sup> [inch <sup>2</sup> ]	13 [0.02]	32 [0.05]	78 [0.121]	83 [0.129]	78 [0.121]
Symbol <b>V</b>	P – A; P – B	mm <sup>2</sup> [inch <sup>2</sup> ]	13 [0.02]	32 [0.05]	73 [0.113]	83 [0.129]	73 [0.113]
	A – T; B – T	mm <sup>2</sup> [inch <sup>2</sup> ]	13 [0.02]	32 [0.05]	84 [0.13]	83 [0.129]	84 [0.13]
Symbol <b>W</b>	A – T; B – T	mm <sup>2</sup> [inch <sup>2</sup> ]	2.4 [0.004]	6 [0.009]	10 [0.015]	14 [0.022]	20 [0.031]
Pilot volume for switching process							
▶ 3-spool position valve, spring-centered		cm <sup>3</sup> [inch <sup>3</sup> ]	2.04 [0.124]	5.72 [0.349]	7.64 [0.466]	14.2 [0.866]	29.4 [1.794]
▶ 2-spool position valve		cm <sup>3</sup> [inch <sup>3</sup> ]	4.08 [0.249]	11.45 [0.699]	15.28 [0.932]	28.4 [1.733]	58.8 [3.588]
▶ 3-spool position valve, pressure-centered							
from zero position in switching position "a"	Type WH	cm <sup>3</sup> [inch <sup>3</sup> ]	–	2.83 [0.173]	–	7.15 [0.436]	14.4 [0.879]
	Type WEH	cm <sup>3</sup> [inch <sup>3</sup> ]	–	2.83 [0.173]	–	7.15 [0.436]	14.4 [0.879]
from switching position "a" in zero position	Type WH	cm <sup>3</sup> [inch <sup>3</sup> ]	–	5.72 [0.349]	–	14.18 [0.865]	29.4 [1.794]
	Type WEH	cm <sup>3</sup> [inch <sup>3</sup> ]	–	2.9 [0.177]	–	7.0 [0.427]	15.1 [0.921]
from zero position in switching position "b"	Type WH	cm <sup>3</sup> [inch <sup>3</sup> ]	–	5.72 [0.349]	–	14.18 [0.865]	29.4 [1.794]
	Type WEH	cm <sup>3</sup> [inch <sup>3</sup> ]	–	5.72 [0.349]	–	14.15 [0.863]	29.4 [1.794]
from switching position "b" in zero position	Type WH	cm <sup>3</sup> [inch <sup>3</sup> ]	–	8.55 [0.522]	–	19.88 [1.213]	43.8 [2.673]
	Type WEH	cm <sup>3</sup> [inch <sup>3</sup> ]	–	2.83 [0.173]	–	5.73 [0.349]	14.4 [0.879]
Pilot flow for shortest switching time, approx.	l/min [US gpm]	35 [9.2]	35 [9.2]	35 [9.2]	35 [9.2]	45 [11.9]	



## Technical data

(For application outside these values, please consult us!)

Druckflüssigkeit	Klassifizierung	Geeignete Dichtungsmaterialien	Normen	Datenblatt
Mineralöle	HL, HLP, HLPD, HVLP, HVLPD	NBR, FKM	DIN 51524	90220
Biologisch abbaubar	▶ wasserunlöslich	HETG	ISO 15380	90221
		HEES		
	▶ wasserlöslich	HEPG	ISO 15380	
Schwerentflammbar	▶ wasserfrei	HFDU (Glykolbasis)	ISO 12922	90222
		HFDU (Esterbasis)		
		HFDR		
	▶ wasserhaltig	HFC (Fuchs: Hydrotherm 46M, Renosafe 500; Petrofer: Ultra Safe 620; Houghton: Safe 620; Union: Carbide HP5046)	ISO 12922	90223



### Important information on hydraulic fluids:

- ▶ For further information and data on the use of other hydraulic fluids, please refer to the data sheets above or contact us.
- ▶ There may be limitations regarding the technical valve data (temperature, pressure range, life cycle, maintenance intervals, etc.).
- ▶ The ignition temperature of the hydraulic fluid used must be 50 K higher than the maximum surface temperature.
- ▶ **Bio-degradable and flame-resistant – containing water:** If this hydraulic fluid is used, small amounts of dissolved zinc may get into the hydraulic system.

### ▶ Flame-resistant – containing water:

- Due to increased cavitation tendency with HFC hydraulic fluids, the life cycle of the component may be reduced by up to 30% as compared to the use with mineral oil HLP. In order to reduce the cavitation effect, it is recommended - if possible specific to the installation - to back up the return flow pressure in ports T to approx. 20% of the pressure differential at the component.
- Depending on the hydraulic fluid used, the maximum ambient and hydraulic fluid temperature must not exceed 50 °C. To reduce the heat input in the component, a maximum duty cycle of 50% must be set for on/off valves in continuous operation (measuring time 300 s). If this is not possible due to the function, an energy-reducing control of these components is recommended, e.g. via a PWM plug-in amplifier.

- 4) ▶ **Internal pilot oil supply:**
- With a higher pilot pressure, use of a **pressure reducing valve "D3"** is required (if it is not used pilot pressure = operating pressure at the port).
  - In connection with version "H", the **pressure reducing valve "D3"** is also required.
- ▶ **External pilot oil supply:**
- Compliance with the maximum pilot pressure must be ensured by appropriate measures (e. g. protection of the separate pilot oil circuit by means of a pressure relief valve)!
- 5) Symbol S only for NG16
- 6) For symbols C, F, G, H, P, T, V, Z, an internal pilot oil supply is

only possible if the flow from P to T in the central position (for 3-spool position valve) or while crossing the central position (for 2-spool position valve) is so large that the pressure differential of P to T reaches a value of at least 7.5 bar [109 psi] and the pilot oil return Y is implemented externally.

- 7) For symbols C, F, G, J, H, P, T, V, Z, S<sup>5)</sup> – by means of preload valve (not NG10) or correspondingly high flow. (Determination of the required flow, see "Preload valve" characteristic curves on page 39.) For NG10, a check valve with a cracking pressure of 7.5 bar [109 psi] is to be provided in the return line to the tank. The pilot oil return Y must be implemented externally.

## Switching times

Pilot pressure		bar [psi]	70 [1015]	210 [3046]	250 [3626]	Spring
			ON			OFF
NG10	▶ Without throttle insert	ms	40 ... 60	–	40 ... 60	20 ... 30
	▶ With throttle insert	ms	60 ... 90	–	50 ... 70	20 ... 30
NG16	▶ Without throttle insert	ms	50 ... 80	–	40 ... 60	50 ... 80
	▶ With throttle insert	ms	110 ... 130	–	80 ... 100	50 ... 80
NG25 ("4W.H 22")	▶ Without throttle insert	ms	40 ... 70	40 ... 60	–	50 ... 70
	▶ With throttle insert	ms	140 ... 160	80 ... 110	–	50 ... 70
NG25 ("4W.H 25")	▶ Without throttle insert	ms	70 ... 100	–	50 ... 70	100 ... 130
	▶ With throttle insert	ms	200 ... 250	–	120 ... 150	100 ... 130
NG32	▶ Without throttle insert	ms	80 ... 130	–	70 ... 100	140 ... 160
	▶ With throttle insert	ms	420 ... 560	–	230 ... 350	140 ... 160

### Notices:

- ▶ Switching times = Contacting at the pilot control valve until start of opening of the control edge in the main valve and change in the control spool stroke by 95%)
- ▶ The switching times are measured according to ISO 6403 with HLP46,  $\vartheta_{oil} = 40 \text{ °C} \pm 5 \text{ °C} [104 \text{ °F} \pm 9 \text{ °F}]$ .  
With different oil temperatures, variations are possible!
- ▶ The switching times were determined using DC solenoids. They decrease by approx. 20 ms if AC solenoids are used.
- ▶ The shut-off of the solenoids creates voltage peaks, which can be reduced by the use of suitable diodes.
- ▶ The switching times increase by approx. 30 ms if the pressure reducing valve "D3" is used.
- ▶ The switching times have been determined under ideal conditions and may differ in the system, depending on the application conditions.

**Characteristic curves: NG10**

 (measured with HLP46,  $\vartheta_{oil} = 40 \pm 5^\circ\text{C}$  [104 ± 9°F])

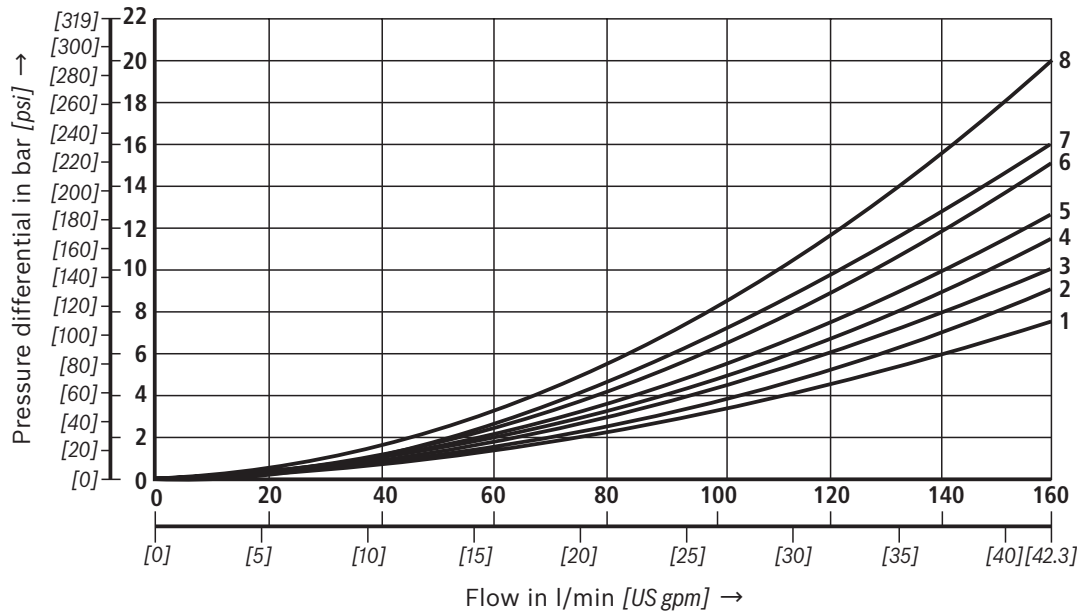
 **$\Delta p$ - $q_V$  characteristic curves**

Symbol	Spool position				Zero position		
	P - A	P - B	A - T <sup>1)</sup>	B - T <sup>1)</sup>	A - T	B - T	P - T
E, Y, D, Q, V, W, Z	1	1	3	5			
F	1	3	1	4	3	-	6
G, T	4	2	4	7	-	-	8
H, C	3	3	1	7	1	5	5
J, K	1	2	1	6			
L	2	2	1	4	2	-	-
M	3	3	2	5			
P	3	1	2	7	-	5	7
R	1	2	3	-			
U	2	2	3	6	-	6	-
A, B	1	1	-	-			

<sup>1)</sup> The pressure differential refers to the use of port T. If port T1 is additionally used, the pressure differential may be lower. If only port T1 is used, the relations A - T and B - T may be reversed.

**Performance limits: NG10**

 (measured with HLP46,  $\vartheta_{oil} = 40 \pm 5^\circ\text{C}$  [104 ± 9°F])

2-spool position valves - $q_{V \max}$ in l/min [US gpm]					
Symbol	Operating pressure $p_{\max}$ in bar [psi]				
	70 [1015]	140 [2030]	210 [3046]	280 [4061]	350 [5076]
<b>X external - spring end position in the main valve</b> <sup>1)</sup> (with $p_{pilot \min} = 12 \text{ bar}$ [174 psi])					
C, D, K, Y, Z	160 [42]	160 [42]	160 [42]	160 [42]	160 [42]
<b>X external - hydraulic end position in the main valve</b>					
HC, HD, HK, HZ, HY	160 [42]	160 [42]	160 [42]	160 [42]	160 [42]

<sup>1)</sup> If the pilot pressure fails, the function of the return spring is no longer guaranteed with the specified flow values!

3-spool position valves - $q_{V \max}$ in l/min [US gpm]					
Symbol	Operating pressure $p_{\max}$ in bar [psi]				
	70 [1015]	140 [2030]	210 [3046]	280 [4061]	350 [5076]
<b>X external - spring-centered</b>					
E, J, L, M, Q, U, V, W, R	160 [42]	160 [42]	160 [42]	160 [42]	160 [42]
F, P	160 [42]	120 [32]	100 [26]	90 [20]	90 [20]
G, T	160 [42]	160 [42]	160 [42]	130 [34]	120 [32]
H	160 [42]	160 [42]	120 [32]	110 [29]	100 [26]

Important notices see page 28.

**Characteristic curves: NG16**  
 (measured with HLP46,  $\vartheta_{oil} = 40 \pm 5 \text{ }^\circ\text{C}$  [ $104 \pm 9 \text{ }^\circ\text{F}$ ])

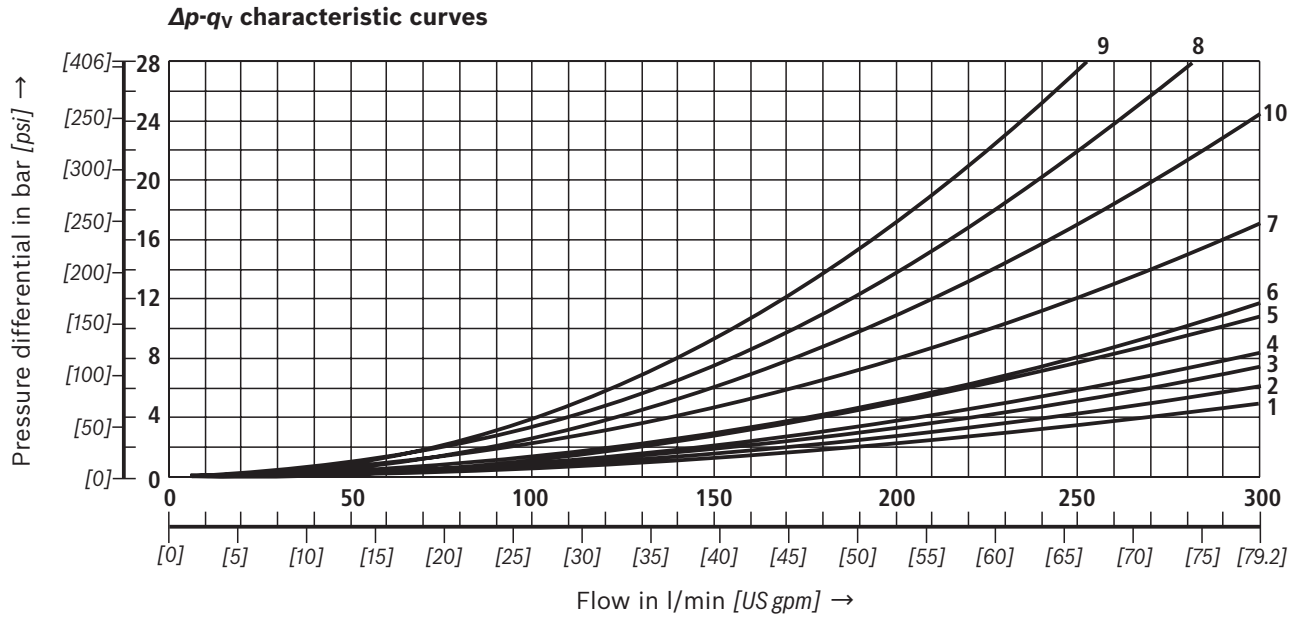

Symbol	Spool position				Zero position		
	P-A	P-B	A-T	B-T	P-T	A-T	B-T
D, E, Y	1	1	3	3			
F	1	2	5	5	4	3	-
G	4	1	5	5	7	-	-
C, H	1	1	5	6	2	4	4
K, J	2	2	6	6	-	3	-
L	2	2	5	4	-	3	-
M	1	1	3	4			
P	2	1	3	6	5	-	-

Symbol	Spool position				Zero position		
	P-A	P-B	A-T	B-T	P-T	A-T	B-T
Q	1	1	6	6			
R	2	4	7	-			
S	3	3	3	-	9	-	-
T	4	1	5	5	7	-	-
U	2	2	3	4			6
V, Z	1	1	6	6	10	8	8
W	1	1	3	4			

**Performance limits: NG16**(measured with HLP46,  $\vartheta_{oil} = 40 \pm 5 \text{ °C}$  [ $104 \pm 9 \text{ °F}$ ])

<b>2-spool position valves – <math>q_{V \max}</math> in l/min [US gpm]</b>					
Symbol	Operating pressure $p_{\max}$ in bar [psi]				
	70 [1015]	140 [2030]	210 [3046]	280 [4061]	350 [5076]
<b>X external – spring end position in the main valve</b> (with $p_{\text{pilot min}} = 12 \text{ bar}$ [174 psi])					
C, D, K, Y, Z	300 [79]	300 [79]	300 [79]	300 [79]	300 [79]
<b>X external – spring end position in the main valve <sup>1)</sup></b>					
C	300 [79]	300 [79]	300 [79]	300 [79]	300 [79]
D, Y	300 [79]	270 [71]	260 [68]	250 [66]	230 [60]
K	300 [79]	250 [66]	240 [63]	230 [60]	210 [55]
Z	300 [79]	260 [68]	190 [50]	180 [47]	160 [42]
<b>X external – hydraulic end position in the main valve</b>					
HC, HD, HK, HZ, HY	300 [79]	300 [79]	300 [79]	300 [79]	300 [79]

<sup>1)</sup> If the specified flow values are exceeded, the function of the return spring is no longer guaranteed if the pilot pressure fails!

<sup>2)</sup> With symbol V, the pilot control valve is not required for flows >160 l/min [42 US gpm].

<b>3-spool position valves – <math>q_{V \max}</math> in l/min [US gpm]</b>					
Symbol	Operating pressure $p_{\max}$ in bar [psi]				
	70 [1015]	140 [2030]	210 [3046]	280 [4061]	350 [5076]
<b>X external – spring-centered</b>					
E, H, J, L, M, Q, U, W, R	300 [79]	300 [79]	300 [79]	300 [79]	300 [79]
F, P	300 [79]	250 [66]	180 [47]	170 [45]	150 [39]
G, T	300 [79]	300 [79]	240 [63]	210 [55]	190 [50]
S	300 [79]	300 [79]	300 [79]	250 [66]	220 [58]
V	300 [79]	250 [66]	210 [55]	200 [53]	180 [47]
<b>X external – pressure-centered</b> (at minimum pilot pressure of 16 bar [232 psi])					
all symbols <sup>2)</sup>	300 [79]	300 [79]	300 [79]	300 [79]	300 [79]

 **Important notices see page 28.**

**Characteristic curves: NG25 ("W.H 22")**  
 (measured with HLP46,  $\vartheta_{oil} = 40 \pm 5 \text{ } ^\circ\text{C}$  [104 ± 9 °F])

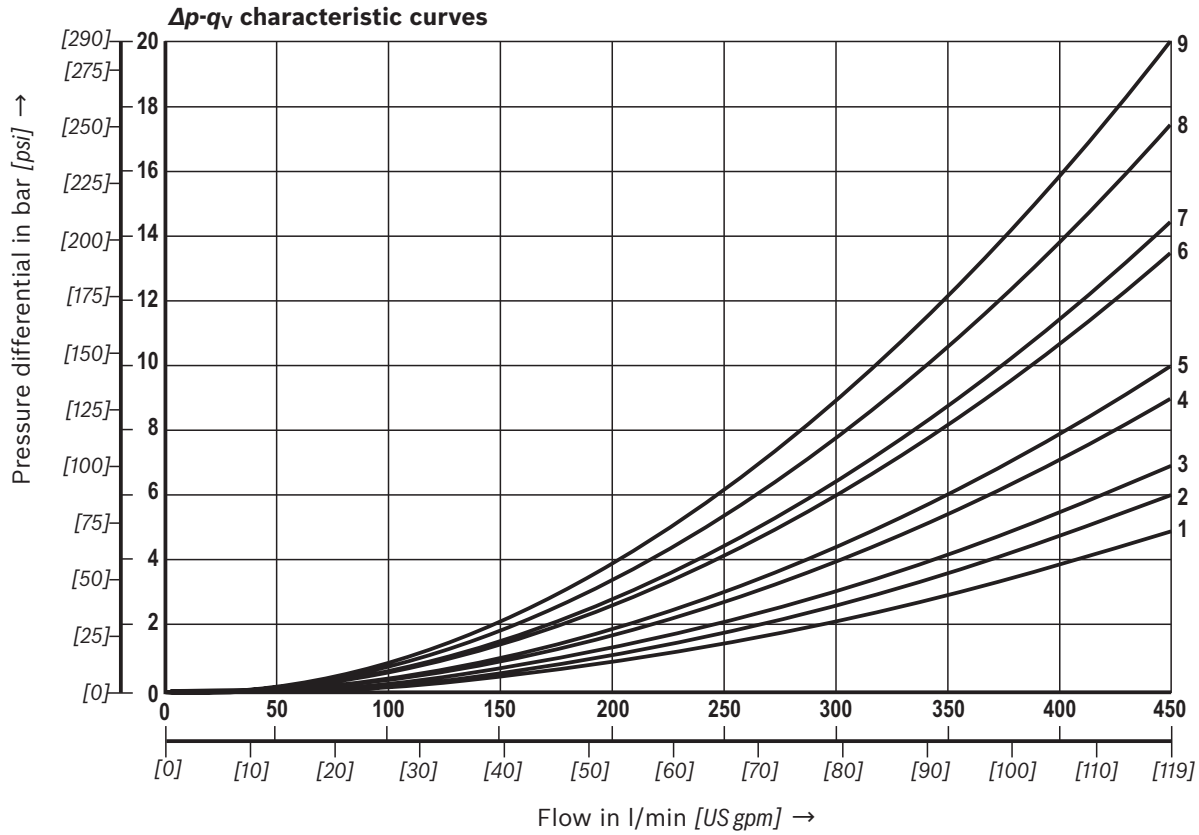

Symbol	Spool position				
	P - A	P - B	A - T	B - T	B - A
E, D	2	2	3	5	-
J, Q, K	2	2	4	6	-
M, W	1	1	3	5	-
H, V, C, Z	1	1	4	6	-
F	1	2	4	5	-
G	3	4	5	6	-
R	1	2	2	-	-
L	2	2	4	5	-
U	2	2	2	6	-
P	2	2	2	7	-
T	4	4	5	6	-

Symbol	Zero position		
	A - T	B - T	P - T
F	2	-	4
G, T	-	-	9
H	-	-	3
L	7	-	-
U	-	6	-
J	8	8	-
P	-	4	6
V, Z	-	-	8

**Performance limits: NG25 ("W.H 22")**  
(measured with HLP46,  $\vartheta_{oil} = 40 \pm 5 \text{ °C}$  [ $104 \pm 9 \text{ °F}$ ])

<b>2-spool position valves – <math>q_{V \max}</math> in l/min [US gpm]</b>					
Symbol	Operating pressure $p_{\max}$ in bar [psi]				
	70 [1015]	140 [2030]	210 [3046]	280 [4061]	350 [5076]
<b>X external – spring end position in the main valve</b> (with $p_{\text{pilot min}} = 11 \text{ bar} / 14 \text{ bar}$ [159 / 203 psi])					
C, D, K, Y, Z	450 [119]	450 [119]	450 [119]	450 [119]	450 [119]
<b>X external – spring end position in the main valve <sup>1)</sup></b>					
C	450 [119]	450 [119]	320 [84]	250 [66]	200 [53]
D, Y	450 [119]	450 [119]	450 [119]	400 [105]	320 [84]
K	450 [119]	215 [57]	150 [39]	120 [32]	100 [26]
Z	350 [92]	300 [79]	290 [76]	260 [68]	160 [42]
<b>X external – hydraulic end position in the main valve</b>					
HC, HD, HK, HZ, HY	450 [119]	450 [119]	450 [119]	450 [119]	450 [119]
HC./O..., HD./O..., HK./O..., HZ./O...	450 [119]	450 [119]	450 [119]	450 [119]	450 [119]
HC./OF..., HD./ OF..., HK./OF..., HZ./OF...	450 [119]	450 [119]	450 [119]	450 [119]	450 [119]

<sup>1)</sup> If the specified flow values are exceeded, the function of the return spring is no longer guaranteed if the pilot pressure fails!

<b>3-spool position valves – <math>q_{V \max}</math> in l/min [US gpm]</b>					
Symbol	Operating pressure $p_{\max}$ in bar [psi]				
	70 [1015]	140 [2030]	210 [3046]	280 [4061]	350 [5076]
X external – spring-centered					
E, J, L, M, Q, U, W, R	450 [119]	450 [119]	450 [119]	450 [119]	450 [119]
H	450 [119]	450 [119]	300 [79]	260 [68]	230 [61]
G	400 [105]	350 [92]	250 [66]	200 [53]	180 [47]
F	450 [119]	270 [71]	175 [46]	130 [34]	110 [29]
V	450 [119]	300 [79]	240 [63]	220 [58]	160 [42]
T	400 [105]	300 [79]	240 [63]	200 [53]	160 [42]
P	450 [119]	270 [71]	180 [47]	170 [45]	110 [29]

 **Important notices see page 28.**

**Characteristic curves: NG25 ("W.H 25")**  
 (measured with HLP46,  $\vartheta_{oil} = 40 \pm 5 \text{ }^\circ\text{C}$  [104  $\pm$  9  $^\circ\text{F}$ ])

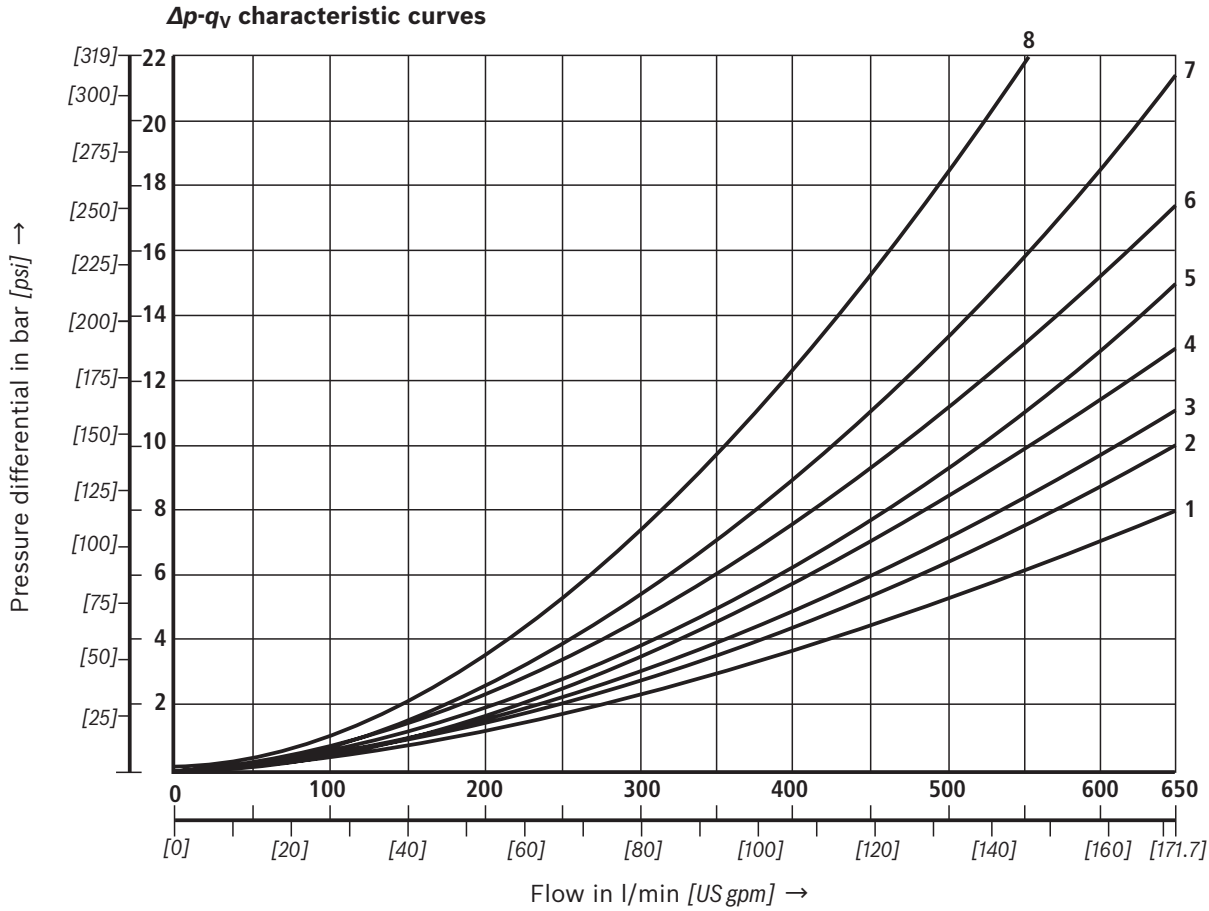

Symbol	Spool position				Zero position		
	P - A	P - B	A - T <sup>1)</sup>	B - T <sup>1)</sup>	A - T	B - T	P - T
E, Y, D	1	1	3	4			
F	1	1	2	4	2	-	5
G, T	1	1	2	5	-	-	7
H	1	1	2	5	2	2	4
C	1	1	2	5			
J	1	1	2	5	6	5	-
K	1	1	2	5			
L	1	1	2	4	5	-	-
M	1	1	3	4			
P	1	1	3	5	-	3	5
Q	1	1	2	3			
R	1	1	3	-			
U	1	1	2	5	-	5	-
V	1	1	2	5	8	7	-
Z	1	1	2	5			
W	1	1	3	4			

<sup>8</sup> Symbol R, spool position B - A



**Performance limits: NG25 ("W.H 25")**  
(measured with HLP46,  $\vartheta_{oil} = 40 \pm 5 \text{ °C}$  [ $104 \pm 9 \text{ °F}$ ])

<b>2-spool position valves – <math>q_{V \max}</math> in l/min [US gpm]</b>					
Symbol	Operating pressure $p_{\max}$ in bar [psi]				
	70 [1015]	140 [2030]	210 [3046]	280 [4061]	350 [5076]
<b>X external – spring end position in the main valve</b> (with $p_{\text{pilot min}} = 13 \text{ bar}$ [188 psi])					
C, D, K, Y, Z	700 [185]	700 [185]	700 [185]	700 [185]	650 [172]
<b>X external – spring end position in the main valve <sup>1)</sup></b>					
C	700 [185]	700 [185]	700 [185]	700 [185]	650 [172]
D, Y	700 [185]	650 [172]	400 [105]	350 [92]	300 [79]
K	700 [185]	650 [172]	420 [111]	370 [98]	320 [84]
Z	700 [185]	700 [185]	650 [172]	480 [127]	400 [105]
<b>X external – hydraulic end position in the main valve</b>					
HC, HD, HK, HZ, HY	700 [185]	700 [185]	700 [185]	700 [185]	700 [185]
HC./O..., HD./O..., HK./O..., HZ./O...	700 [185]	700 [185]	700 [185]	700 [185]	700 [185]
HC./OF..., HD./OF..., HK./OF..., HZ./OF...	700 [185]	700 [185]	700 [185]	700 [185]	700 [185]

<sup>1)</sup> If the specified flow values are exceeded, the function of the return spring is no longer guaranteed if the pilot pressure fails!

<b>3-spool position valves – <math>q_{V \max}</math> in l/min [US gpm]</b>					
Symbol	Operating pressure $p_{\max}$ in bar [psi]				
	70 [1015]	140 [2030]	210 [3046]	280 [4061]	350 [5076]
<b>X external – spring-centered</b>					
E, L, M, Q, U, W	700 [185]	700 [185]	700 [185]	700 [185]	650 [172]
G, T	400 [105]	400 [105]	400 [105]	400 [105]	400 [105]
F	650 [172]	550 [145]	430 [113]	330 [87]	300 [79]
H	700 [185]	650 [172]	550 [145]	400 [105]	360 [95]
J	700 [185]	700 [185]	650 [172]	600 [158]	520 [137]
P	650 [172]	550 [145]	430 [113]	330 [87]	300 [79]
V	650 [172]	550 [145]	400 [105]	350 [92]	310 [82]
R	700 [185]	700 [185]	700 [185]	650 [172]	580 [153]
<b>X external – pressure-centered</b> (at minimum pilot pressure of 18 bar [261 psi])					
E, F, H, J, L, M, P, Q, R, U, V, W	700 [185]	700 [185]	700 [185]	700 [185]	650 [172]
G, T	400 [105]	400 [105]	400 [105]	400 [105]	400 [105]
<b>X external – pressure-centered</b> (with pilot pressure > 30 bar [435 psi])					
G, T	700 [185]	700 [185]	700 [185]	700 [185]	650 [172]

 Important notices see page 28.

**Characteristic curves: NG32**  
 (measured with HLP46,  $\vartheta_{oil} = 40 \pm 5 \text{ }^\circ\text{C}$  [104 ± 9 °F])

**$\Delta p$ - $q_v$ -characteristic curves – Symbol E, R and W**

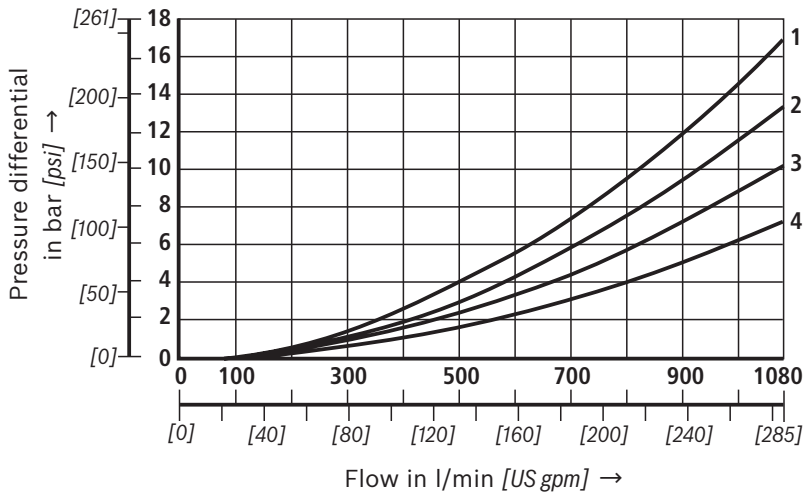

Symbol	Spool position				
	P - A	P - B	A - T	B - T	B - A
E	4	4	3	2	-
R	4	4	3	-	1
W	4	4	3	2	-

**$\Delta p$ - $q_v$  characteristic curves – Symbol G and T**

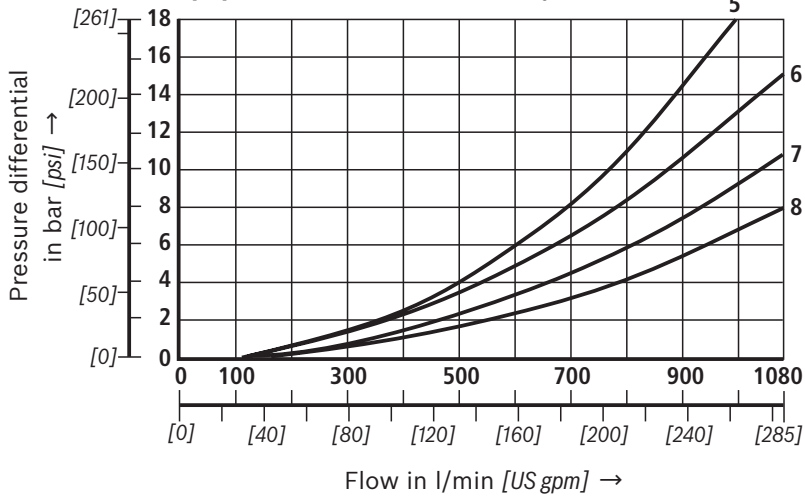

Symbol	Spool position				
	P - A	P - B	A - T	B - T	P - T
G	7	8	7	5	6
T	7	8	7	5	6

**Performance limits: NG32**(measured with HLP46,  $\vartheta_{oil} = 40 \pm 5 \text{ °C}$  [ $104 \pm 9 \text{ °F}$ ])

<b>2-spool position valves – <math>q_{V \max}</math> in l/min [US gpm]</b>					
Symbol	Operating pressure $p_{\max}$ in bar [psi]				
	70 [1015]	140 [2030]	210 [3046]	280 [4061]	350 [5076]
<b>X external – spring end position in the main valve</b> (with $p_{\text{pilot min}} = 10 \text{ bar}$ [145 psi])					
C, D, K, Y, Z	1100 [290]	1040 [275]	860 [227]	750 [198]	680 [179]
<b>X external – spring end position in the main valve <sup>1)</sup></b>					
C	1100 [290]	1040 [275]	860 [227]	800 [211]	700 [185]
D, Y	1100 [290]	1040 [275]	540 [142]	480 [127]	420 [111]
K	1100 [290]	1040 [275]	860 [227]	500 [132]	450 [119]
Z	1100 [290]	1040 [275]	860 [227]	700 [185]	650 [172]
<b>X external – hydraulic end position in the main valve</b>					
HC, HD, HK, HZ, HY	1100 [290]	1040 [275]	860 [227]	750 [198]	680 [179]

<sup>1)</sup> If the specified flow values are exceeded, the function of the return spring is no longer guaranteed if the pilot pressure fails!

<b>3-spool position valves – <math>q_{V \max}</math> in l/min [US gpm]</b>					
Symbol	Operating pressure $p_{\max}$ in bar [psi]				
	70 [1015]	140 [2030]	210 [3046]	280 [4061]	350 [5076]
<b>X external – spring-centered</b>					
E, J, L, M, Q, R, U, W	1100 [290]	1040 [275]	860 [227]	750 [198]	680 [179]
G, T, H, F, P	900 [238]	900 [238]	800 [211]	650 [172]	450 [119]
V	1100 [290]	1000 [264]	680 [179]	500 [132]	450 [119]
<b>X external – pressure-centered</b> (at minimum pilot pressure of 8.5 bar [123 psi])					
all symbols	1100 [290]	1040 [275]	860 [227]	750 [198]	680 [179]

 Important notices see page 28.

**Performance limits:** important information **Notice** (applies to all sizes):

The specified switching power limits apply to the use with two directions of flow (e. g. from P to A and simultaneous return flow from B to T at a ratio of 1:1). Due to the flow forces acting within the valves, the admissible switching power limit may be considerably lower with only one direction of flow (e. g. from P to A

while port B is blocked, with flow in the same or in different directions)!

In such cases of application, please consult us!

**The switching power limit was established while the solenoids were at operating temperature, at 10% undervoltage, and without tank preloading.**

<b>NG16</b>	<ul style="list-style-type: none"> <li>▶ With pilot oil supply <b>X internal</b>, a preload valve has to be used for flows &lt; 160 l/min [42 US gpm] due to the negative overlap of the symbols C, Z and HC, HZ.</li> <li>▶ 4/3 directional valves with pressure centering of the control spool in the main valve can be used above the indicated performance limit. In this case, a higher pilot pressure is required (values see performance limits of the corresponding size).</li> <li>▶ With pilot oil supply <b>X internal</b>, sufficient flow needs to be ensured due to the negative overlap of symbols F, G, H, P, S and T (for determination of the required flow, see "Preload valve" characteristic curves (page 39). If the required flow is not reached, a preload valve has to be used (see page 16).</li> </ul>
<b>NG25</b> ("W.H 22")	<ul style="list-style-type: none"> <li>▶ With pilot oil supply <b>X internal</b>, a preload valve has to be used for flows &lt; 180 l/min [47.5 US gpm] due to the negative overlap of symbols Z, HZ and V.</li> <li>▶ With pilot oil supply <b>X internal</b>, sufficient flow needs to be ensured due to the negative overlap of symbols C, HC, F, G, H, P and T (for determination of the required flow, see "Preload valve" characteristic curves (page 39). If the required flow is not reached, a preload valve has to be used (see page 16).</li> </ul>
<b>NG25</b> ("W.H 25")	<ul style="list-style-type: none"> <li>▶ With pilot oil supply <b>X internal</b>, a preload valve has to be used for flows &lt; 180 l/min [47.5 US gpm] due to the negative overlap of symbols Z, HZ and V.</li> <li>▶ 4/3 directional valves with pressure centering of the control spool in the main valve can be used above the indicated performance limit. In this case, a higher pilot pressure is required (values see performance limits of the corresponding size).</li> <li>▶ With pilot oil supply <b>X internal</b>, sufficient flow needs to be ensured due to the negative overlap of symbols C, HC, F, G, H, P and T (for determination of the required flow, see "Preload valve" characteristic curves (page 39). If the required flow is not reached, a preload valve has to be used (see page 16).</li> </ul>
<b>NG32</b>	<ul style="list-style-type: none"> <li>▶ With pilot oil supply <b>X internal</b>, a preload valve has to be used for flows &lt; 180 l/min [47.5 US gpm] due to the negative overlap of symbols Z, HZ and V.</li> <li>▶ 4/3 directional valves with pressure centering of the control spool in the main valve can be used above the indicated performance limit. In this case, a higher pilot pressure is required (values see performance limits of the corresponding size).</li> <li>▶ With pilot oil supply <b>X internal</b>, sufficient flow needs to be ensured due to the negative overlap of symbols C, HC, F, G, H, P and T (for determination of the required flow, see "Preload valve" characteristic curves (page 39). If the required flow is not reached, a preload valve has to be used (see page 16).</li> </ul>

**Dimensions: NG10**  
(dimensions in mm [inch])

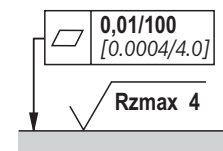
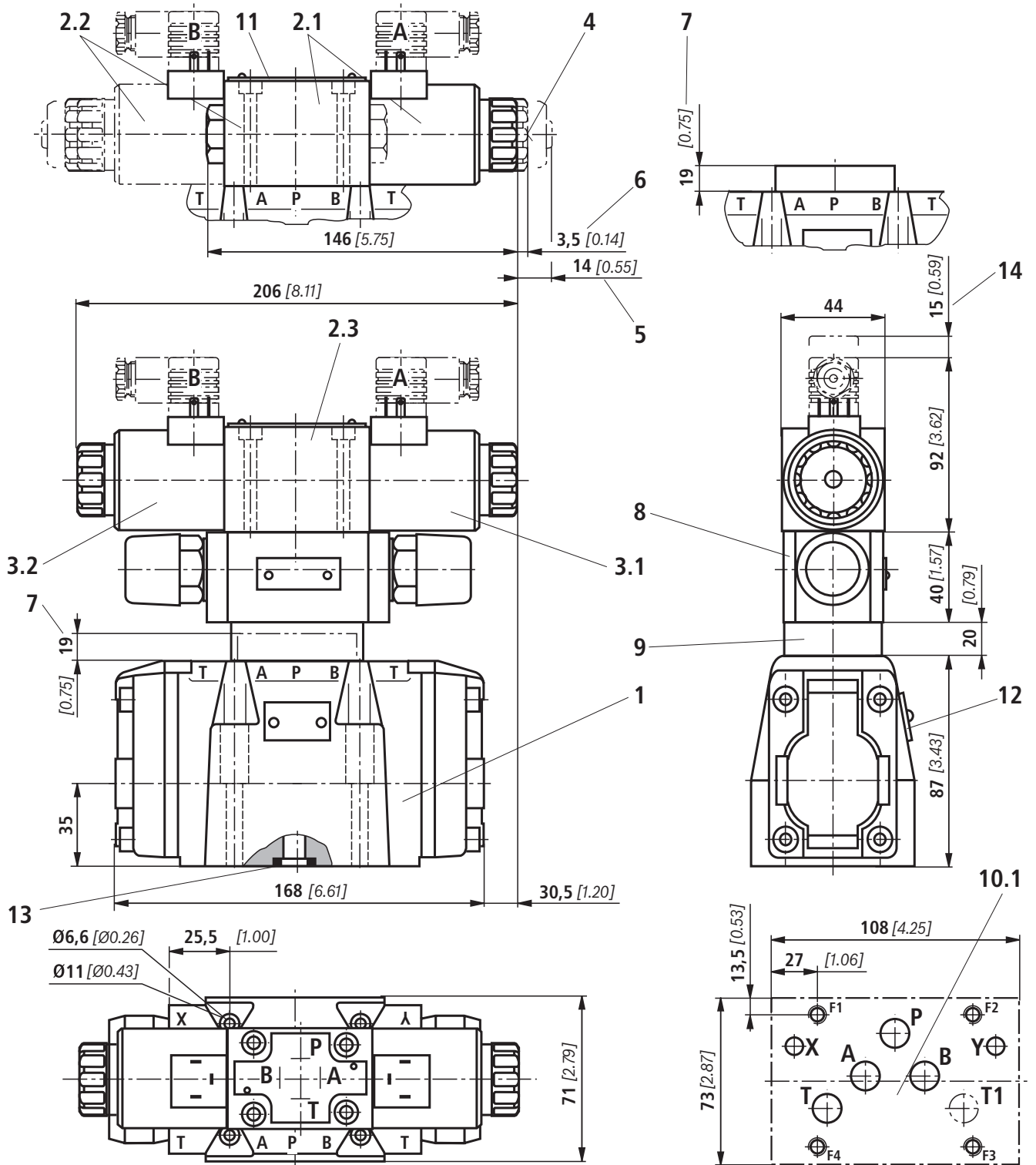

Required surface quality of the valve contact surface

**Notice:**

The dimensions are nominal dimensions which are subject to tolerances.

For item explanations and subplates see page 34.  
Valve mounting screws see page 35.

**Dimensions: NG16**  
(dimensions in mm [inch])

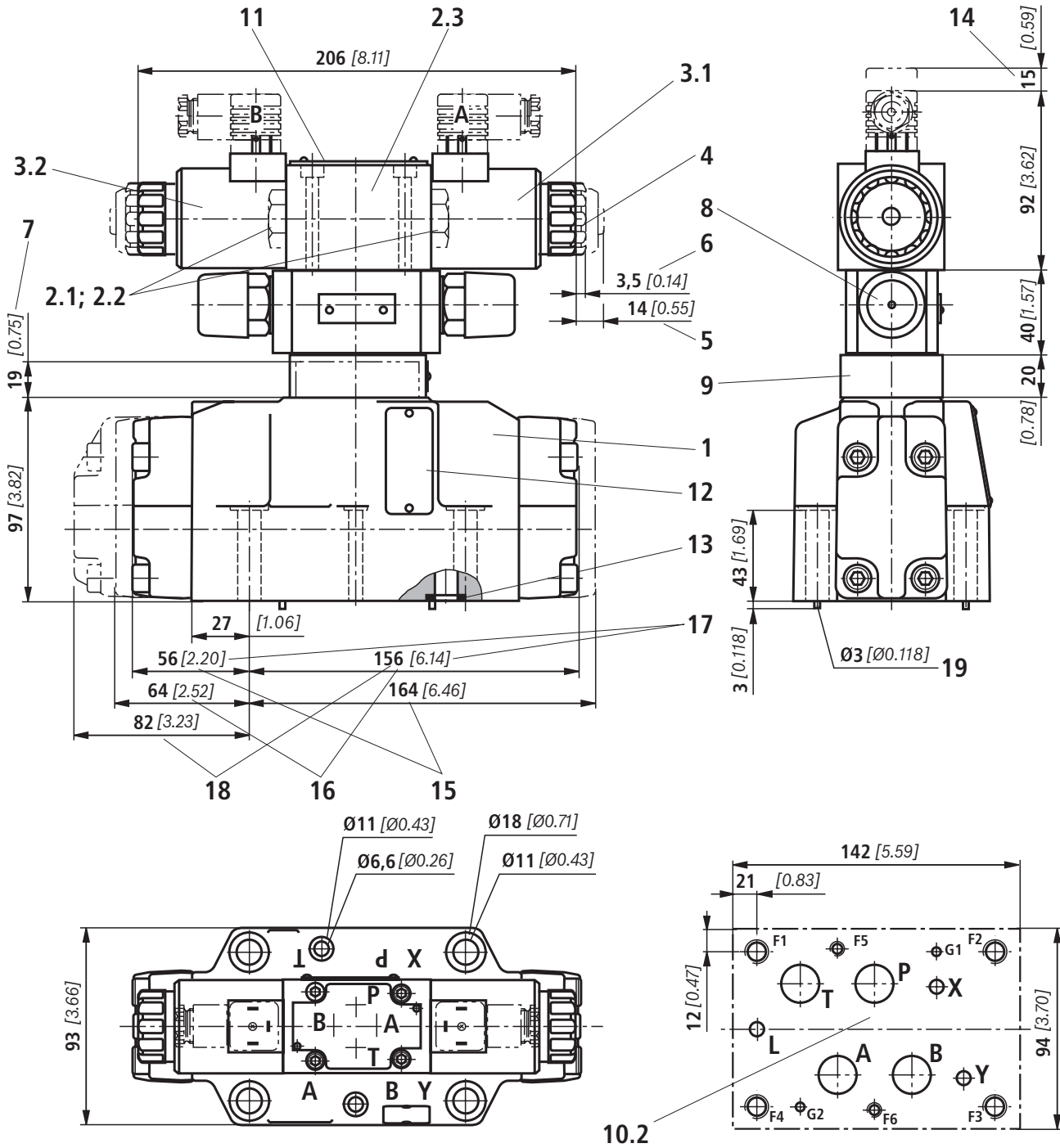

For item explanations and subplates see page 34.  
Valve mounting screws see page 35.



**Notice:**

The dimensions are nominal dimensions which are subject to tolerances.

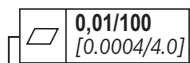

Rzmax 4

Required surface quality of the valve contact surface

**Dimensions:** NG25 ("W.H 22")  
(dimensions in mm [inch])

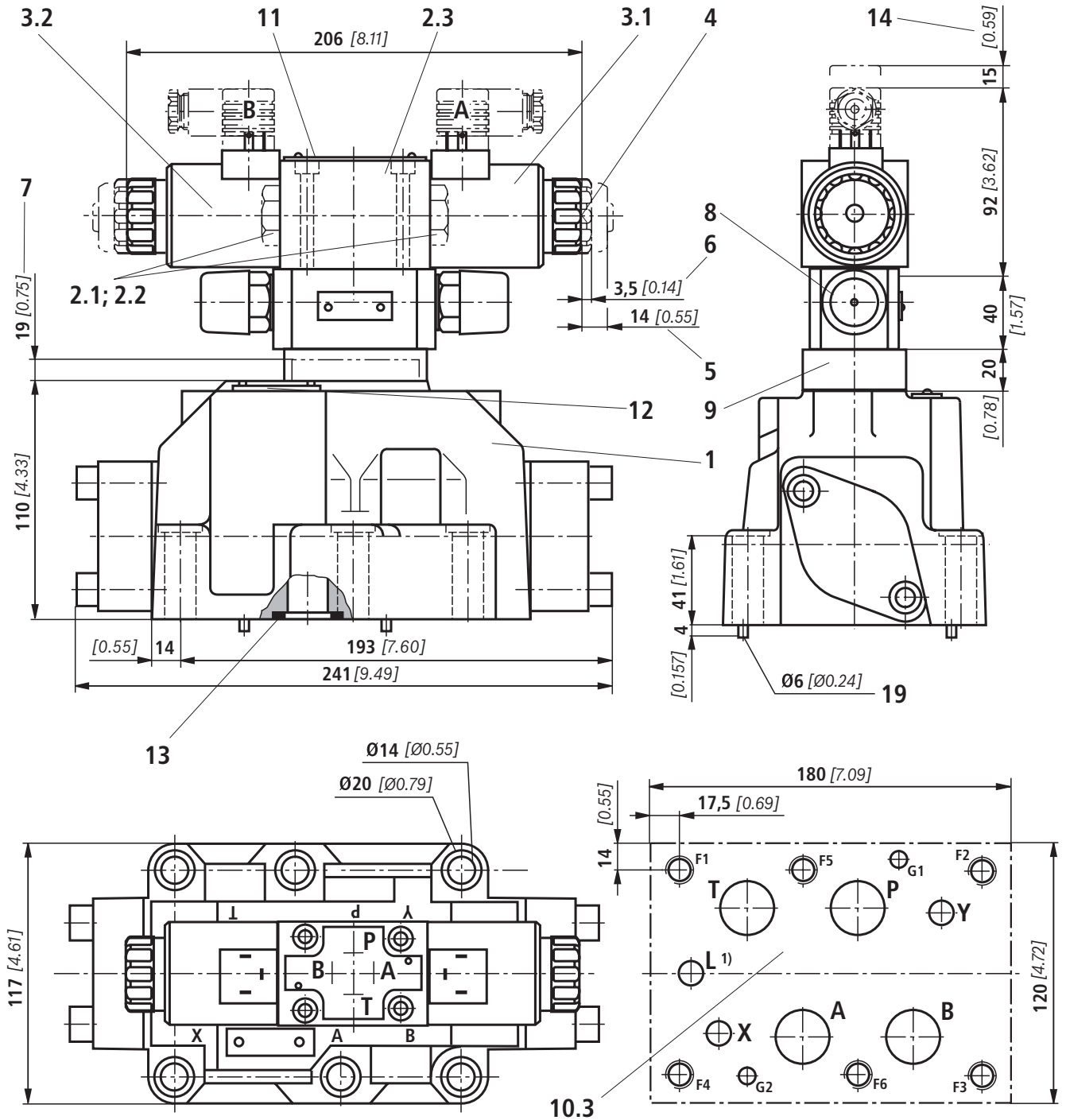

1) Port L only for valves with pressure-centered zero position

**For item explanations and subplates see page 34.**  
**Valve mounting screws see page 35.**

**Notice:**

The dimensions are nominal dimensions which are subject to tolerances.

0,01/100  
[0.0004/4.0]

Rzmax 4

Required surface quality of the valve contact surface





**Dimensions:** NG32  
(dimensions in mm [inch])

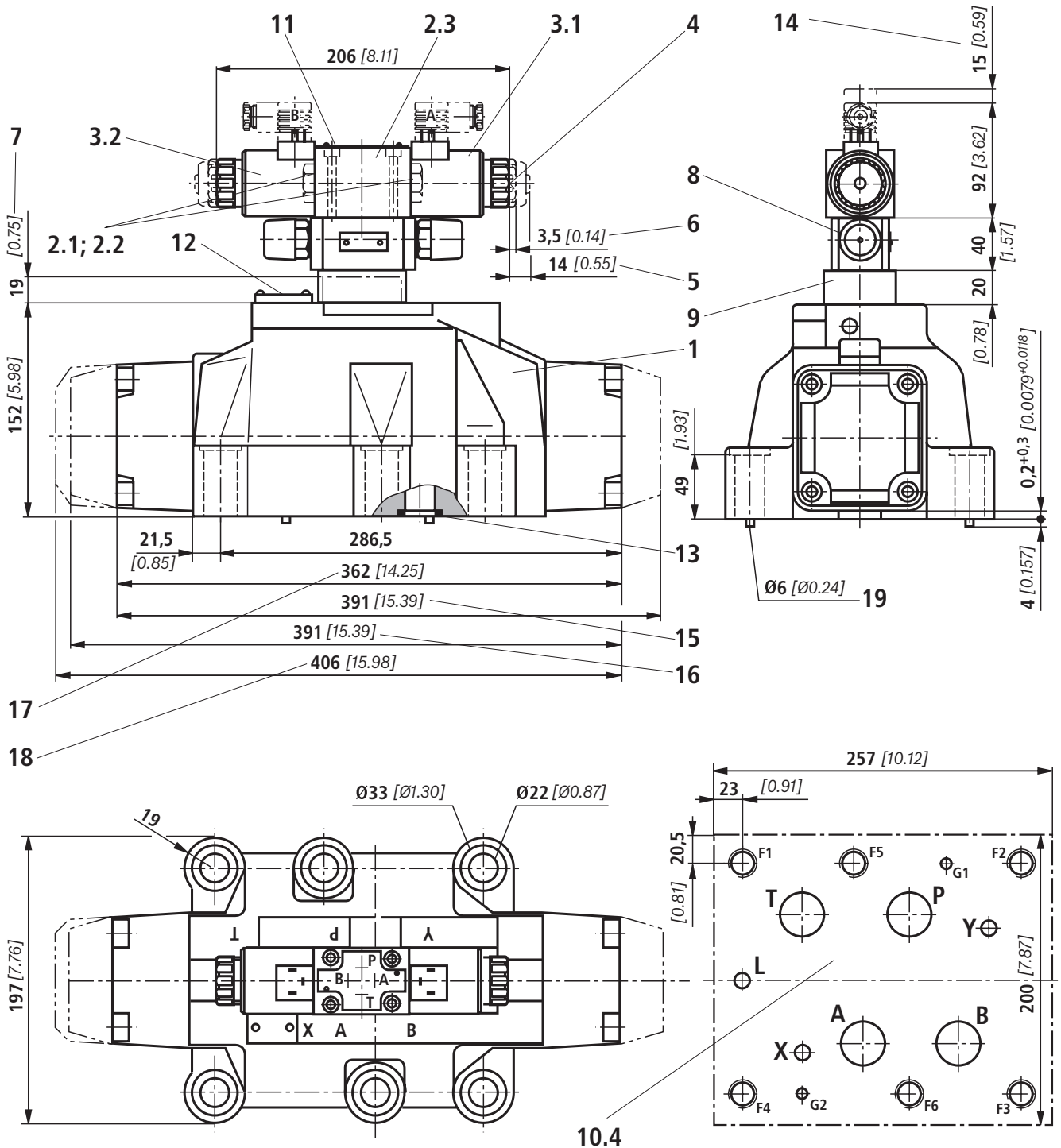

For item explanations and subplates see page 34.  
Valve mounting screws see page 35.

**Notice:**

The dimensions are nominal dimensions which are subject to tolerances.

$\square$  0,01/100  
[0.0004/4.0]  
Rzmax 4  
Required surface quality of the valve contact surface

## Dimensions

- 1 Main valve
- 2 Pilot control valve type 4WE 6 ... (data sheet 23178):
- 2.1 ▶ Pilot control valve type 4WE 6 D... (1 solenoid) for main valves with symbols C, D, K, Z symbols HC, HD, HK, HZ
  - ▶ Pilot control valve type 4WE 6 JA... (1 solenoid "a") for main valves with symbols EA, FA, etc., spring return
  - ▶ Pilot control valve type 4WE 6 MA... (1 solenoid "a") for main valves with symbols HEA, HFA, etc., hydraulic spool return
- 2.2 ▶ Pilot control valve type 4WE 6 Y... (1 solenoid) for main valves with symbol Y symbol HY
  - ▶ Pilot control valve type 4WE 6 JB... (1 solenoid "b") for main valves with symbols EB, FB, etc., spring return
  - ▶ Pilot control valve type 4WE 6 MB... (1 solenoid "b") for main valves with symbols HEB, HFB, etc., hydraulic spool return
- 2.3 ▶ Pilot control valve type 4WE 6 J... (2 solenoids) for main valves with 3 spool positions, spring-centered
  - ▶ Pilot control valve type 4WE 6 M... (2 solenoids) for main valves with 3 spool positions, pressure-centered
- 3.1 Solenoid "a"
- 3.2 Solenoid "b"
- 4 Manual override, "N", optional
  - ▶ Actuation of the manual override is only possible up to a tank pressure of approx. 50 bar. Avoid damage to the bore of the manual override! (Special tool for the operation, separate order, material no. **R900024943**). When the manual override is blocked, the operation of the solenoid must be prevented!
  - ▶ Simultaneous actuation of the solenoids must be prevented.
- 5 Solenoid **without** manual override
- 6 Solenoid **with** manual override
- 7 Height of the diversion plate with hydraulic actuation (type WH...)
- 8 Switching time adjustment (wrench size 6), optional
- 9 Pressure reducing valve, optional
- 10.1 Machined valve contact surface; porting pattern according to ISO 4401-05-05-0-05 and NFPAT3.5.1 R2-D05
- 10.2 Machined valve contact surface; porting pattern according to ISO 4401-07-07-0-05 and NFPAT3.5.1 R2-D07
- 10.3 Machined valve contact surface; porting pattern according to ISO 4401-08-08-0-05 and NFPAT3.5.1 R2-D08
- 10.4 Machined valve contact surface; porting pattern according to ISO 4401-10-09-0-05 and NFPAT3.5.1 R2-D10
- 11 Name plate pilot control valve
- 12 Name plate complete valve
- 13 Seal rings
- 14 Space required for removing the mating connector
- 15 2-spool position valves with spring end position in the main valve (symbols A, C, D, K, Z)
- 16 2-spool position valves with spring end position in the main valve (symbols B, Y)

- 17 3-spool position valves, spring-centered; 2-spool position valves with hydraulic end position in the main valve
- 18 3-spool position valves, pressure-centered
- 19 Locking pin

**Subplates** (separate order) with porting pattern according to ISO 4401 see data sheet 45100.

**Valve mounting screws see page 35.**

## Dimensions

### Valve mounting screws (separate order)

Nominal size	Quantity	Hexagon socket head cap screws	Material number
10	4	ISO 4762 - M6 x 45 - 10.9-CM-Fe-ZnNi-5-Cn-T0-H-B Friction coefficient $\mu_{\text{total}} = 0.09 \dots 0.14$ ; tightening torque $M_A = 12.5 \text{ Nm [9.2 ft-lbs]} \pm 10 \%$	R913043777
	or		
	4	1/4-20 UNC x 1 3/4" ASTM-A574	Not included in the Rexroth delivery range
16	4	ISO 4762 - M10 x 60 - 10.9-fZn/nc/480h/C Friction coefficient $\mu_{\text{total}} = 0.09 \dots 0.14$ ; tightening torque $M_A = 58 \text{ Nm [42.8 ft-lbs]} \pm 10 \%$	R913014770
	2	ISO 4762 - M6 x 60 - 10.9-CM-Fe-ZnNi-5-Cn-T0-H-B Friction coefficient $\mu_{\text{total}} = 0.09 \dots 0.14$ ; tightening torque $M_A = 12.5 \text{ Nm [9.2 ft-lbs]} \pm 10 \%$	R913043410
	or		
	4	Zylinderschrauben UNC 3/8-16 UNC x 2 1/4" ASTM-A574	Not included in the Rexroth delivery range
	2	Zylinderschrauben UNC 1/4-20 UNC x 2 1/4" ASTM-A574	
25	6	ISO 4762 - M12 x 60 - 10.9-fZn/nc/480h/C Friction coefficient $\mu_{\text{total}} = 0.09 \dots 0.14$ ; tightening torque $M_A = 100 \text{ Nm [74 ft-lbs]} \pm 20 \%$	R913015613
	or		
	6	UNC 1/2-13 UNC x 2 1/2" ASTM-A574	Not included in the Rexroth delivery range
32	6	ISO 4762 - M20 x 80 - 10.9-fZn/nc/480h/C Friction coefficient $\mu_{\text{total}} = 0.09 \dots 0.14$ ; tightening torque $M_A = 340 \text{ Nm [251 ft-lbs]} \pm 10 \%$	R913008472
	or		
	6	UNC 3/4-10 UNC x 3 1/4" ASTM-A574	Not included in the Rexroth delivery range

**Stroke setting, mounting options**  
(dimensions in mm [inch])

The stroke of the control spool is limited by the stroke setting (1). The control spool stroke is shortened by loosening the lock nut (2) and clockwise rotation of the adjustment spindle (3). The control chamber (4) must be depressurized for this.

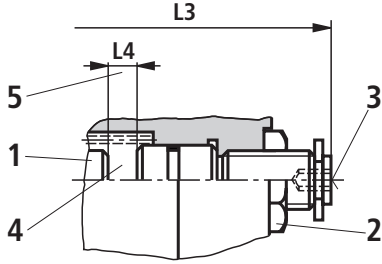

NG	L4
10	6.5 [0.26]
16	10 [0.39]
25 ("W.H 22")	9.5 [0.37]
25 ("W.H 25")	12.5 [0.49]
32	15 [0.59]

More dimensions see below and page 37.

- 5 Adjustment range**
- ▶ NG10:  
1 rotation = 1 mm [0.0394 inch] adjustment travel
  - ▶ NG16 and 32:  
1 rotation = 1.5 mm [0.0591 inch] adjustment travel

**Stroke limitation on side A**

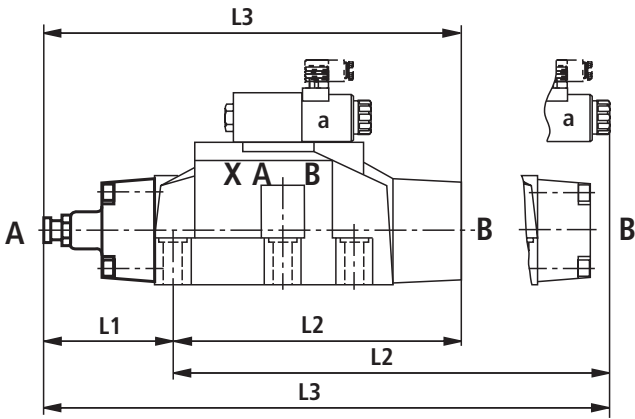

**Stroke limitation on side B**

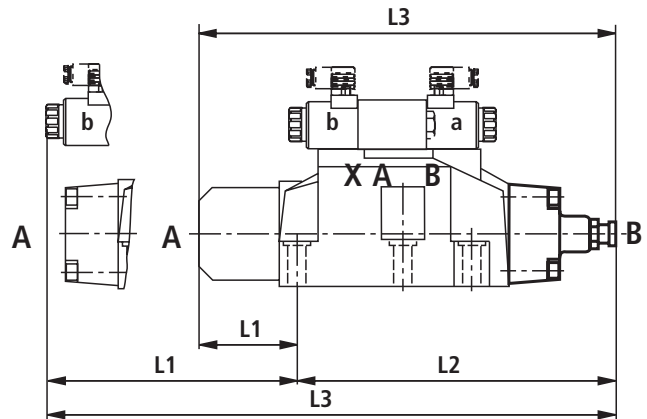

**3-spool position valve 1)**

			spring-centered			pressure-centered		
			L1	L2	L3	L1	L2	L3
Stroke setting on valve side A and B	<b>10</b>	10	90 [3.54]	144 [5.67]	234 [9.21]			
		16	100 [3.94]	200 [7.87]	300 [11.81]			
		25 2)	96 [3.77]	241 [9.49]	337 [13.27]			
		25 3)	123 [4.84]	276 [10.87]	399 [15.71]			
		32	133 [5.24]	344 [13.54]	477 [18.78]			
Stroke setting on valve side A	<b>11</b>	10	90 [3.54]	106 [4.17]	196 [7.72]			
		16	100 [3.94]	156 [6.14]	256 [10.08]			
		25 2)	96 [3.77]	193 [7.60]	289 [11.38]			
		25 3)	123 [4.84]	225 [8.86]	348 [13.70]			
		32	133 [5.24]	287 [11.30]	420 [16.54]			
Stroke setting on valve side B	<b>12</b>	10	52 [2.05]	144 [5.67]	196 [7.72]	-	-	-
		16	56 [2.20]	200 [7.87]	256 [10.08]	81 [3.19]	200 [7.87]	281 [11.06]
		25 2)	48 [1.89]	241 [9.49]	289 [11.38]	-	-	-
		25 3)	72 [2.83]	276 [10.87]	348 [13.70]	107 [4.21]	276 [10.87]	283 [11.14]
		32	76 [2.99]	344 [13.54]	420 [16.54]	120 [4.72]	344 [13.54]	464 [18.27]

1) With symbol A only version "11", with symbol B only version "12" possible.

## Stroke setting, mounting options

(dimensions in mm [inch])

### 2-spool position valve

			Spring end position						Hydraulic end position		
			A, C, D, K, Z			B, Y			HC, HD, HK, HZ, HY		
			L1	L2	L3	L1	L2	L3	L1	L2	L3
Stroke setting on valve side A and B	<b>10</b>	10	90 [3.54]	144 [5.67]	234 [9.21]	90 [3.54]	144 [5.67]	234 [9.21]	90 [3.54]	144 [5.67]	234 [9.21]
		16	-	-	-	-	-	-	100 [3.94]	200 [7.87]	300 [11.81]
		25 <sup>2)</sup>	96 [3.78]	241 [9.49]	337 [13.27]	96 [3.78]	241 [9.49]	337 [13.27]	96 [3.78]	241 [9.49]	337 [13.27]
		25 <sup>3)</sup>	-	-	-	-	-	-	123 [4.84]	276 [10.87]	399 [15.71]
		32	-	-	-	-	-	-	133 [5.24]	344 [13.54]	477 [18.78]
Stroke setting on valve side A	<b>11</b>	10	90 [3.54]	106 [4.17]	196 [7.72]	90 [3.54]	106 [4.17]	196 [7.72]	90 [3.54]	106 [4.17]	196 [7.72]
		16	100 [3.94]	180 [7.09]	280 [11.02]	-	-	-	100 [3.94]	156 [6.14]	256 [10.08]
		25 <sup>2)</sup>	96 [3.78]	193 [7.60]	289 [11.38]	96 [3.78]	193 [7.60]	289 [11.38]	96 [3.78]	193 [7.60]	289 [11.38]
		25 <sup>3)</sup>	123 [4.84]	253 [9.96]	376 [14.8]	-	-	-	123 [4.84]	225 [8.86]	348 [13.70]
		32	133 [5.24]	316 [12.44]	449 [17.68]	-	-	-	133 [5.24]	287 [11.30]	420 [16.53]
Stroke setting on valve side B	<b>12</b>	10	52 [2.05]	144 [5.67]	196 [7.72]	52 [2.05]	144 [5.67]	196 [7.72]	52 [2.05]	144 [5.67]	196 [7.72]
		16	-	-	-	80 [3.15]	200 [7.87]	280 [11.02]	56 [2.21]	200 [7.87]	256 [10.08]
		25 <sup>2)</sup>	48 [1.89]	241 [9.49]	289 [11.38]	48 [1.89]	241 [9.49]	289 [11.38]	48 [1.89]	241 [9.49]	289 [11.38]
		25 <sup>3)</sup>	-	-	-	100 [3.94]	276 [10.87]	376 [14.80]	72 [2.84]	276 [10.87]	348 [13.70]
		32	-	-	-	105 [4.13]	344 [13.54]	449 [17.68]	76 [2.99]	344 [13.54]	420 [16.53]

<sup>2)</sup> Version "W.H 22"

<sup>3)</sup> Version "W.H 25"



#### Notice:

The dimensions are nominal dimensions which are subject to tolerances.

## Switching time adjustment

The switching time of the main valve (1) is influenced by using a twin throttle check valve (2) (type Z2FS 6; data sheet 27506).

### Modification of supply (3) to discharge control (4):

Remove the pilot control valve (5) – The plate (6) to accept the seal rings stays in place – Turn the switching time adjustment (2) around its longitudinal axis and put it back, install the pilot control valve (5).

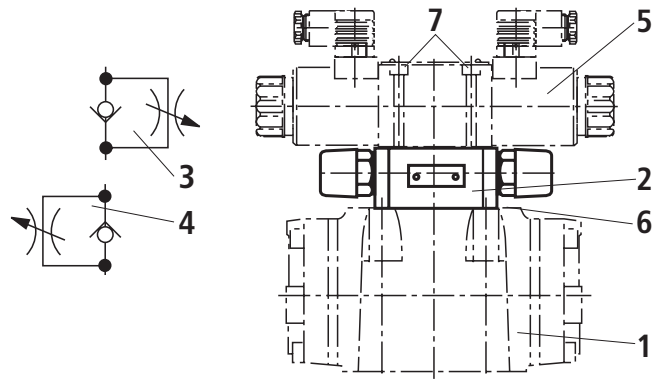

Type .WEH 10 ..4X/...S  
Type .WEH 10 ..4X/...S2

#### Notice:

The modification may only be performed by authorized specialists or at the factory!

## Pressure reducing valve "D3"

The pressure reducing valve (8) has to be used at a pilot pressure above 250 bar [3626 psi] (with "WEH 22 ...": 210 bar [3046 psi]) and with version "H".

The secondary pressure is kept at a constant level of 45 bar [652 psi].

#### Notice:

- ▶ If a pressure reducing valve "D3" (8) is used, a "B10" throttle insert has to be installed in channel P of the pilot control valve.
- ▶ The modification may only be performed by authorized specialists or at the factory!

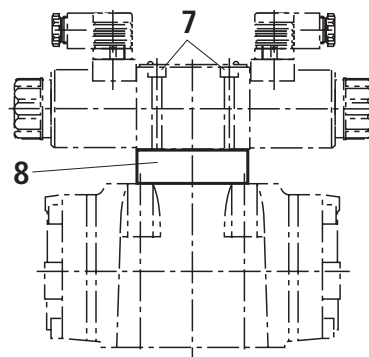

Type .WEH 10 ..4X/.../..D3

## Preload valve (not for NG10)

In case of valves with depressurized circulation and internal pilot oil supply, the installation of the preload valve (9) in channel P of the main valve is required in order to build up the minimum pilot pressure.

The pressure differential of the preload valve is to be added to the pressure differential of the main valve (see characteristic curves) to result in one total value. The cracking pressure amounts to approx. 4.5 bar [65 psi].



- 9.1 Preload valve
- 9.2 Preload valve
- 10 Main valve
- 11 Subplate

**Notice:**  
Series-production status, see ordering key on the name plate.

Size	Item 9.1	Item 9.2
16	R961009415 (from component series 72)	R961009417 (up to component series 71)
25 ("W.H 22")	–	R961009609 (up to component series 76)
25 ("W.H 25")	R961009166 (from component series 68)	R961009416 (up to component series 67)
32	–	R961009610 (up to component series 63)

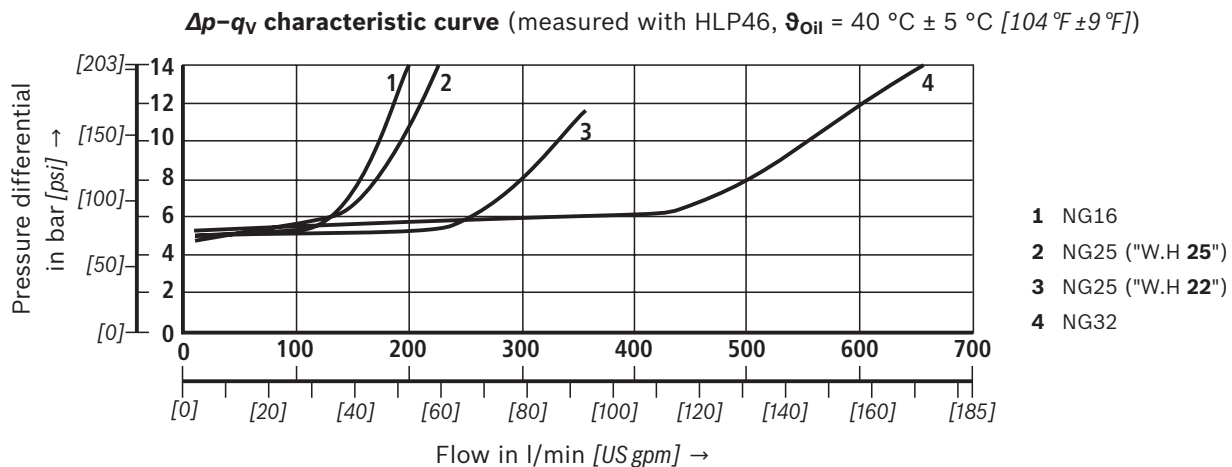

## Project planning information

The stipulations of the Machinery Directive 2006/42/EC are to be adhered to!

Please also note data sheet 08012 with information on MTTFd values and shock and vibration loads!

## Further information

- |   |  |
|---|--|
| ▶ Directional spool valve   | Data sheet 23178   |
| ▶ Subplates   | Data sheet 45100   |
| ▶ Inductive position switch and proximity sensors (contactless)   | Data sheet 24830   |
| ▶ Hydraulic fluids on mineral oil basis   | Data sheet 90220   |
| ▶ Environmentally compatible hydraulic fluids   | Data sheet 90221   |
| ▶ Flame-resistant, water-free hydraulic fluids  | Data sheet 90222   |
| ▶ Flame-resistant hydraulic fluids - containing water (HFAE, HFAS, HFB, HFC)                                  | Data sheet 90223   |
| ▶ Reliability characteristics according to EN ISO 13849   | Data sheet 08012   |
| ▶ Hexagon socket head cap screw, metric/UNC   | Data sheet 08936   |
| ▶ Hydraulic valves for industrial applications  | Operating instructions 07600-B   |
| ▶ General product information on hydraulic products   | Data sheet 07008   |
| ▶ Assembly, commissioning and maintenance of industrial valves  | Data sheet 07300   |
| ▶ Mating connectors and cable sets for valves and sensors in hydraulics                                       | Data sheet 08006   |
| ▶ Directional spool valves and directional seat valves with electrical actuation and M12x1 plug-in connection | Data sheet 08010   |
| ▶ Use of non-electrical hydraulic components in an explosive environment (ATEX)                               | Data sheet 07011   |
| ▶ Selection of filters  | <a href="http://www.boschrexroth.com/filter">www.boschrexroth.com/filter</a> |
| ▶ Information on available spare parts  | <a href="http://www.boschrexroth.com/spc">www.boschrexroth.com/spc</a>       |

Bosch Rexroth AG  
Industrial Hydraulics  
Zum Eisengießer 1  
97816 Lohr am Main, Germany  
Phone +49 (0) 93 52/40 30 20  
[my.support@boschrexroth.de](mailto:my.support@boschrexroth.de)  
[www.boschrexroth.de](http://www.boschrexroth.de)

© All rights reserved to Bosch Rexroth AG, also regarding any disposal, exploitation, reproduction, editing, distribution, as well as in the event of applications for industrial property rights.  
The data specified above only serve to describe the product. No statements concerning a certain condition or suitability for a certain application can be derived from our information. The information given does not release the user from the obligation of own judgment and verification.  
Please note that our products are subject to a natural process of wear and aging.